



Stainless steel multistage horizontal pump. Suitable for clean water, pressurizing system: irrigation, drinking and glycol water, water treatment, heating and air conditioning, washing system.

### Construction features

<b>Pump body, mechanical seal housing</b>	stainless steel AISI 304
<b>Motor bracket</b>	aluminum
<b>Impellers, diffusers</b>	stainless steel AISI 304
<b>Mechanical seal</b>	ceramic-graphite-EPDM
<b>Motor shaft</b>	stainless steel AISI 303
<b>Liquid temperature</b>	-15 ÷ +110 °C
<b>Operating pressure</b>	max 7 bar

### Motor

	3~ 230/400V-50Hz
<b>2 poles induction motor</b>	1~ 230V-50Hz (with thermal protection up to 1.85 kW)
<b>Insulation class</b>	F
<b>Protection degree</b>	IPX4

### P 3 S A - 100/5 T

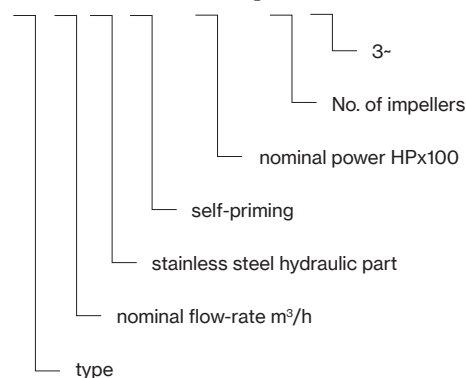

TYPE	TRUCK		CONTAINER	
	PALLET (cm)	N° pumps	PALLET (cm)	N° pumps
<b>P 3SA-90/4</b>	85×110×160	70	85×110×185	80
<b>P 3SA-100/5</b>	80×120×150	42	80×120×175	49
<b>P 5SA-120/4</b>	80×120×150	42	80×120×175	49
<b>P 5SA-150/5</b>	80×120×150	42	80×120×175	49



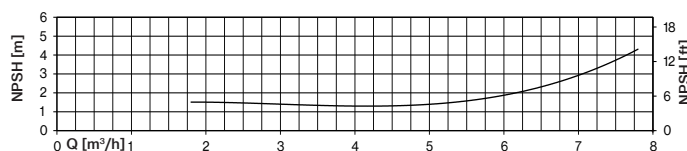
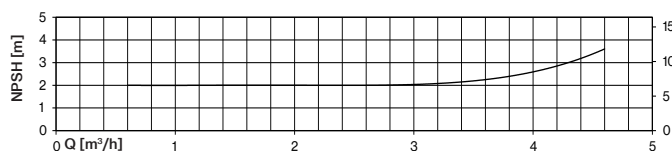
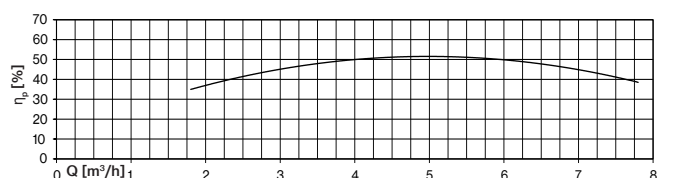
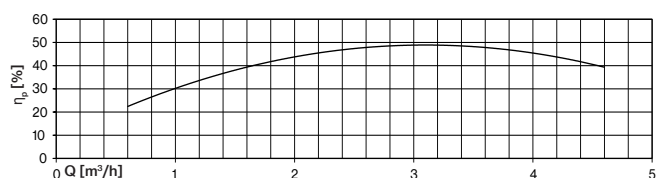
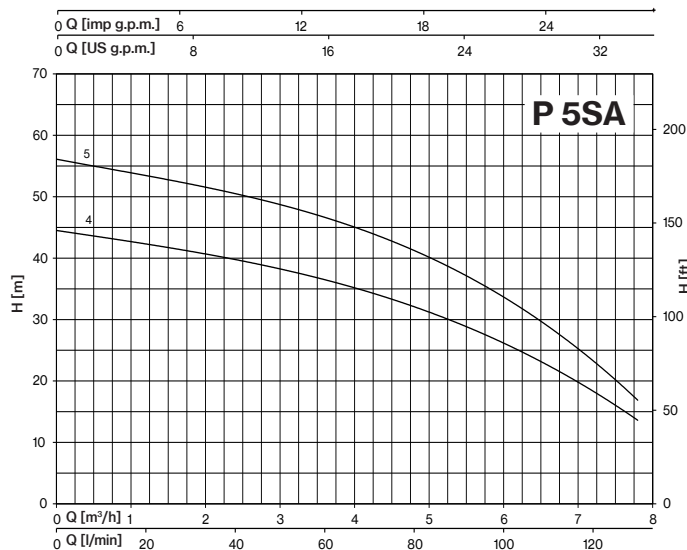
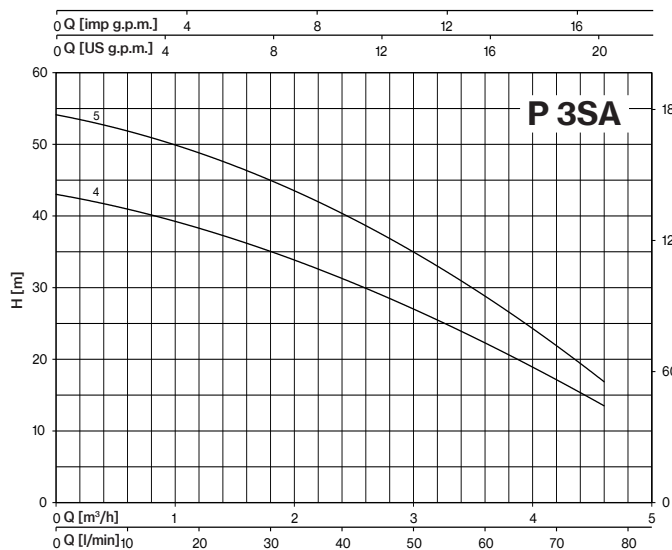

TYPE		P2		P1 (kW)		AMPERE		Q (m³/h - l/min)																	
1~	3~	HP	kW	1~	3~	1x230 V 50 Hz	3x400 V 50 Hz	H (m)																	
								0	0,6	1,2	1,8	2,4	3,6	4,6	4,8	6	7	7,8							
P 3SA-90/4	P 3SA-90/4 T	0,9	0,66	0,83	0,8	3,6	1,7	43,0	41,0	38,3	35,0	31,3	22,3	13,5											
P 3SA-100/5	P 3SA-100/5 T	1	0,75	0,99	0,92	4,4	1,7	54,0	52,1	48,8	44,9	40,2	29,0	16,8											
P 5SA-120/4	P 5SA-120/4 T	1,2	0,9	1,09	1,08	4,9	2,4	44,5			41,0	40,0	36,4	32,8	32,0	26,2	18,5	13,5							
P 5SA-150/5	P 5SA-150/5 T	1,5	1,1	1,39	1,31	6,5	2,7	56,0			52,4	50,5	46,4	42,0	41,0	33,8	23,8	16,5							

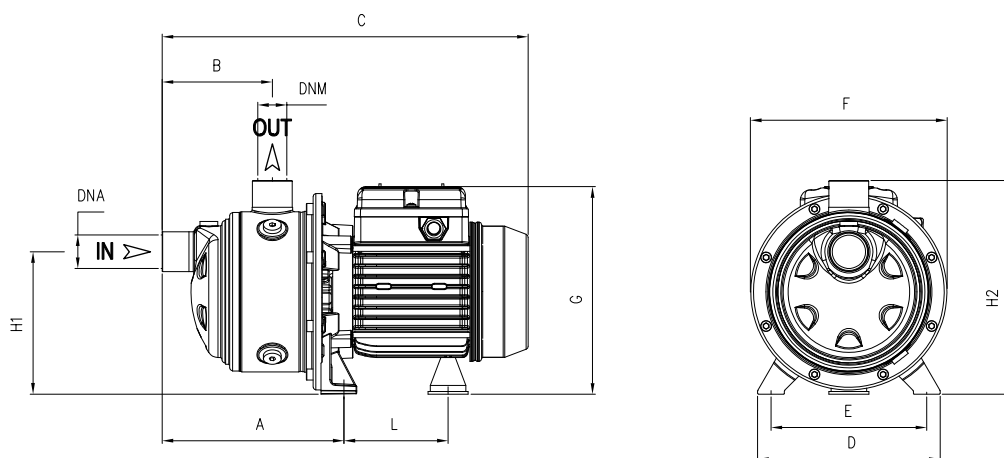

TYPE	DIMENSIONS (mm)											DNA	DNM	Kg	
	A	B	C	D	E	F	G	L	H1	H2					
P 3SA-90/4	190,8	175	405	164	140	178	190	93,7	128	192					10
P 3SA-100/5	214,8	199	452	164	140	178	203	104,7	128	192					12,5
P 5SA-120/4	190,8	175	428	164	140	178	203	104,7	128	192	1" G	1" G			12,5
P 5SA-150/5	214,8	199	514	164	140	201	211	128,2	134	198					15,5