



Medium delivery centrifugal pumps for small and medium agricultural applications. Open impeller which allows small solid items to pass through (Ø max 10 mm).

### Construction features

<b>Pump body</b>	cast iron
<b>Motor bracket</b>	cast iron
<b>Impeller</b>	Noryl® or brass
<b>Mechanical seal</b>	ceramic-graphite-NBR
<b>Motor shaft</b>	stainless steel AISI 416
<b>Liquid temperature</b>	Noryl® impeller: 0 - 50 °C brass impeller: 0 - 90 °C
<b>Operating pressure</b>	max 6 bar

### Motor

	3~ 230/400V-50Hz
<b>2 Poles induction motor</b>	1~ 230V-50Hz (with thermal protection)
<b>Insulation class</b>	F
<b>Protection degree</b>	IPX4

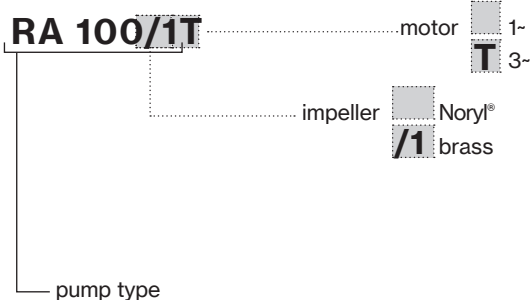

TYPE	LOTS			
	TRUCK		CONTAINER	
	PALLET (cm)	N° pumps	PALLET (cm)	N° pumps
<b>RA</b>	85×110×145	65	85×110×195	91



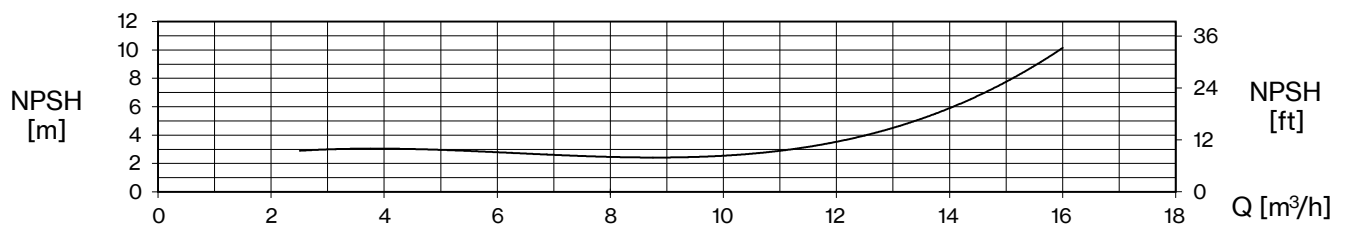
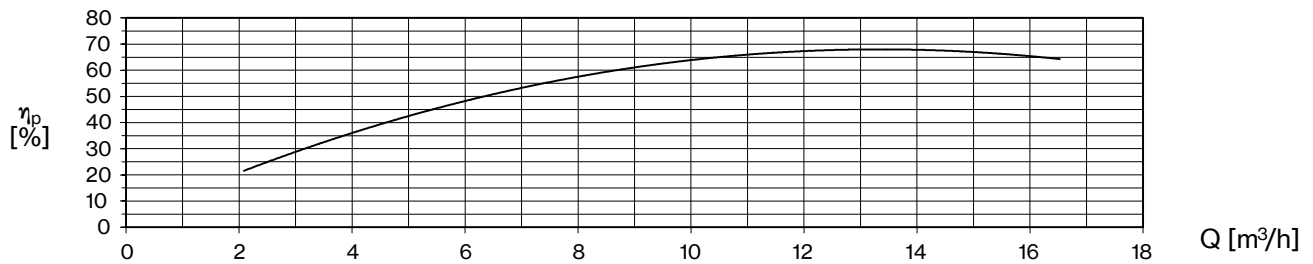
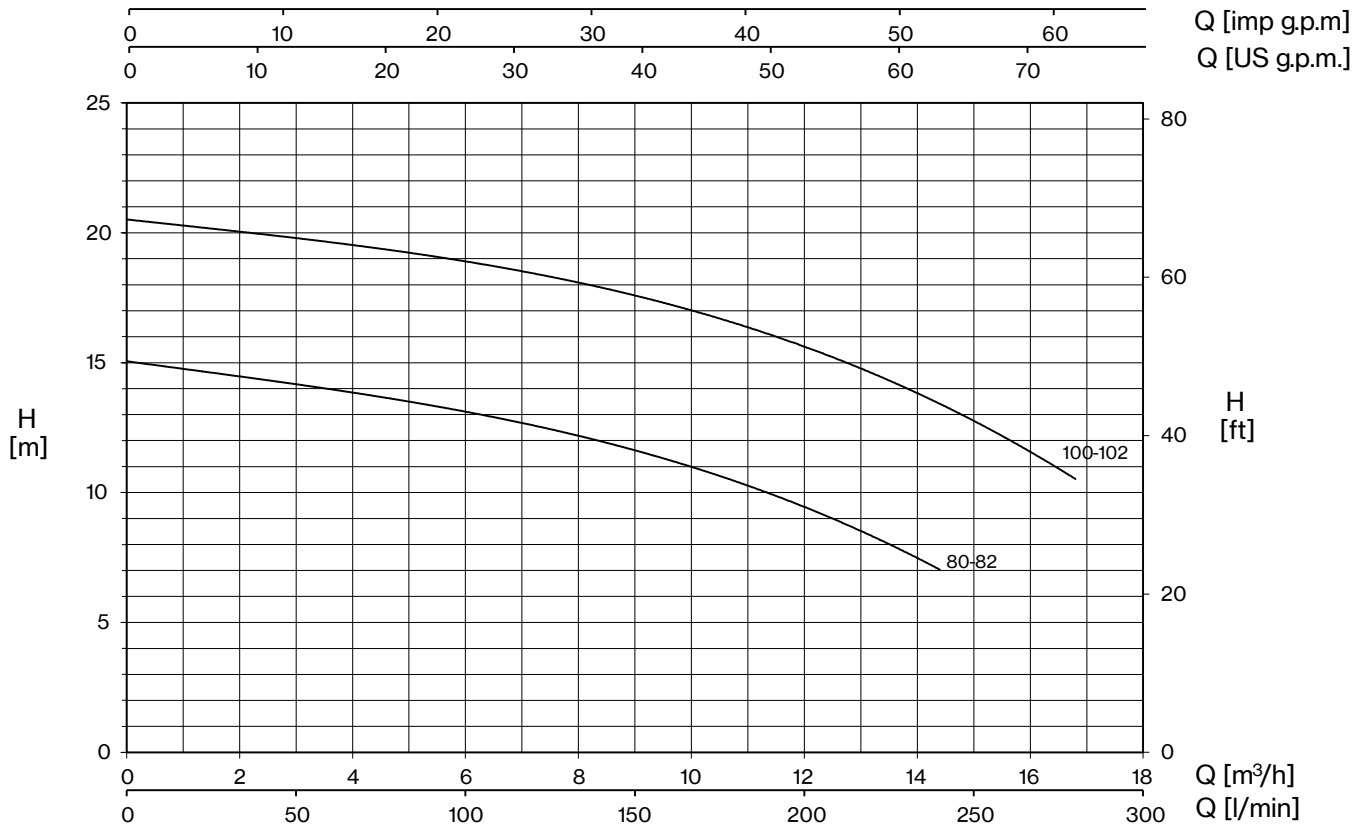

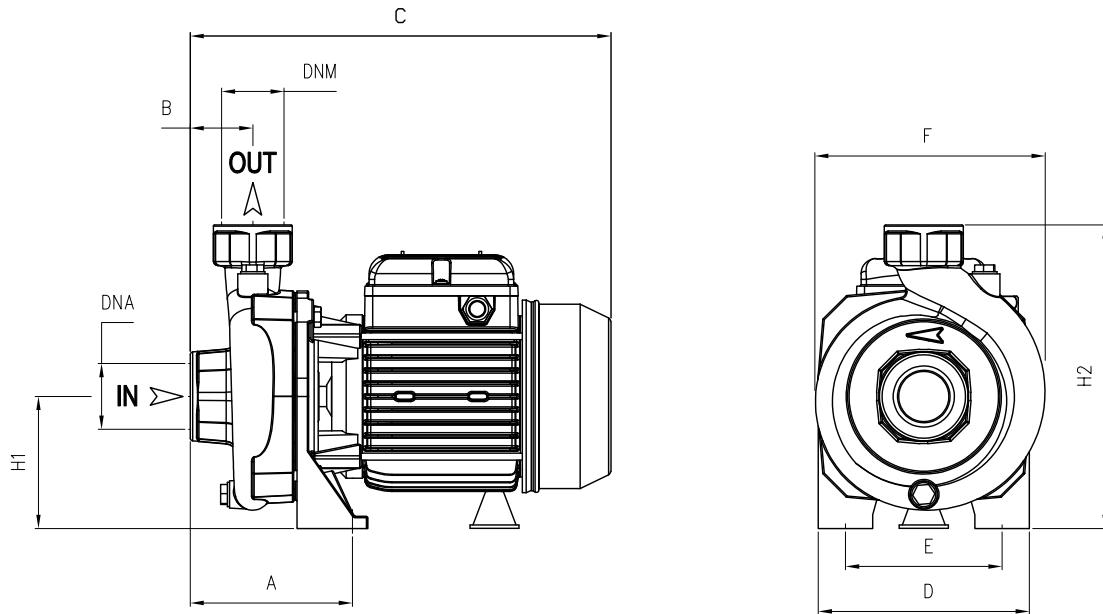

TYPE		P2		P1 (kW)		AMPERE		Q (m³/h - l/min)						
1~	3~					1~	3~	0	3	6	9	12	14,4	16,8
		1x230 V 50 Hz	3x400 V 50 Hz	0	50									
		HP	kW	1~	3~	H (m)								
RA 80	RA 82 T	0,8	0,59	0,73	0,83	3,4	1,5	15,0	14,3	13,0	11,6	9,5	7,0	
RA 82	RA 82 T	0,8	0,59	0,73	0,83	3,4	1,5	15,0	14,3	13,0	11,6	9,5	7,0	
RA 100	RA 100 T	1	0,74	1,14	1,20	5,3	2,4	20,5	19,8	18,9	17,7	15,5	13,5	10,5
RA 102	RA 102 T	1	0,74	1,14	1,20	5,3	2,4	20,5	19,8	18,9	17,7	15,5	13,5	10,5

# RA



TYPE	DIMENSIONS (mm)													
	A	B	C	D	E	F	H1	H2	DNA	DNM	I	L	M	
RA 80	120	45	308	155	115	170	97	222	1" 1/2 G	1" 1/4 G	325	200	265	13
RA 82	120	45	308	155	115	170	97	222		1" 1/2 G	325	200	265	13
RA 100	120	45	308	155	115	170	97	222		1" 1/4 G	325	200	265	14
RA 102	120	45	308	155	115	170	97	222		1" 1/2 G	325	200	265	14