

2KB



Pressurisation units with 2 threaded centrifugal pumps of KB series on a single skid, connected in parallel by suction and delivery manifolds.

They are available in fixed speed version with electronic control panel or in variable speed version with EPIC and EPIC-A inverters for constant pressure. The key characteristics of these systems are their reliability, user-friendly operation, and low maintenance needs. Installation of a pressure tank is required.

Booster set features

Suction manifold	galvanized steel with non-return and isolation valves
Delivery manifold	galvanized steel with pressure gauge and isolation valves, two connectors in the delivery manifold for direct installation of pressure tanks up to 24 lt
Base frame	galvanized steel
Fixed speed	electronic control panel EQ2SM(T) and two pressure switches
Variable speed	inverter EPIC or EPIC-A on each pump and two pressure sensors
Pressure tanks	available on request as accessories

Pump features

Pump body	cast iron
Motor bracket	cast iron
Impeller	Noryl® or brass (100÷900) brass (750÷1500)
Mechanical seal	ceramic-graphite-NBR
Motor shaft	stainless steel AISI 303 stainless steel AISI 416 (100)
Liquid temperature	Noryl® impeller: 0 - 50 °C brass impeller: 0 - 90 °C
Operating pressure	max 6 bar (100) max 11 bar (160÷1500)
2 Poles induction motor	3~ 230/400V - 50Hz P ≤ 4kW 3~ 400/690V - 50Hz P > 4kW 1~ 230V - 50Hz
Motor insulation class	F
Motor protection degree	IPX4 IPX5 (750÷1500)

Name key

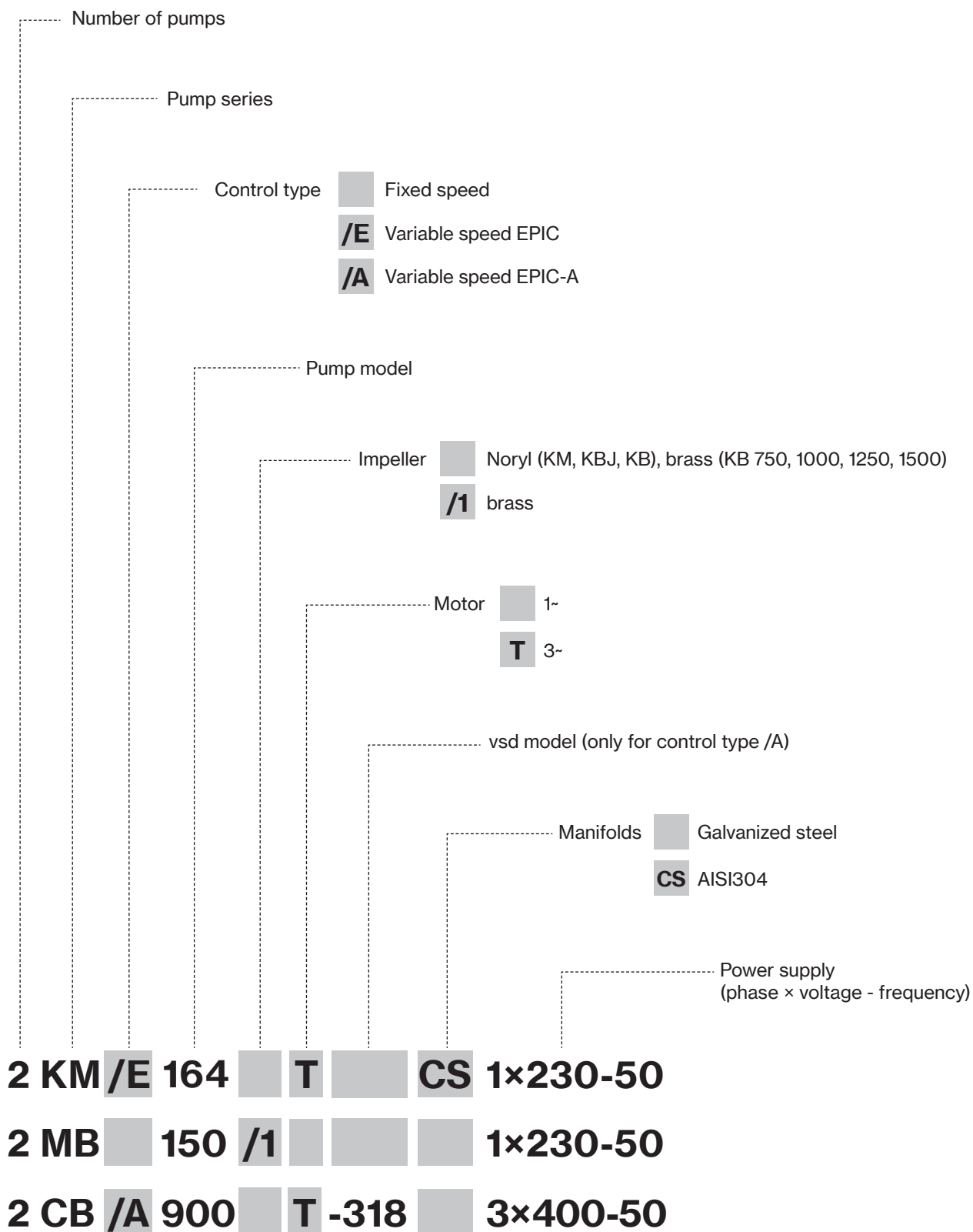

Performance data and curves

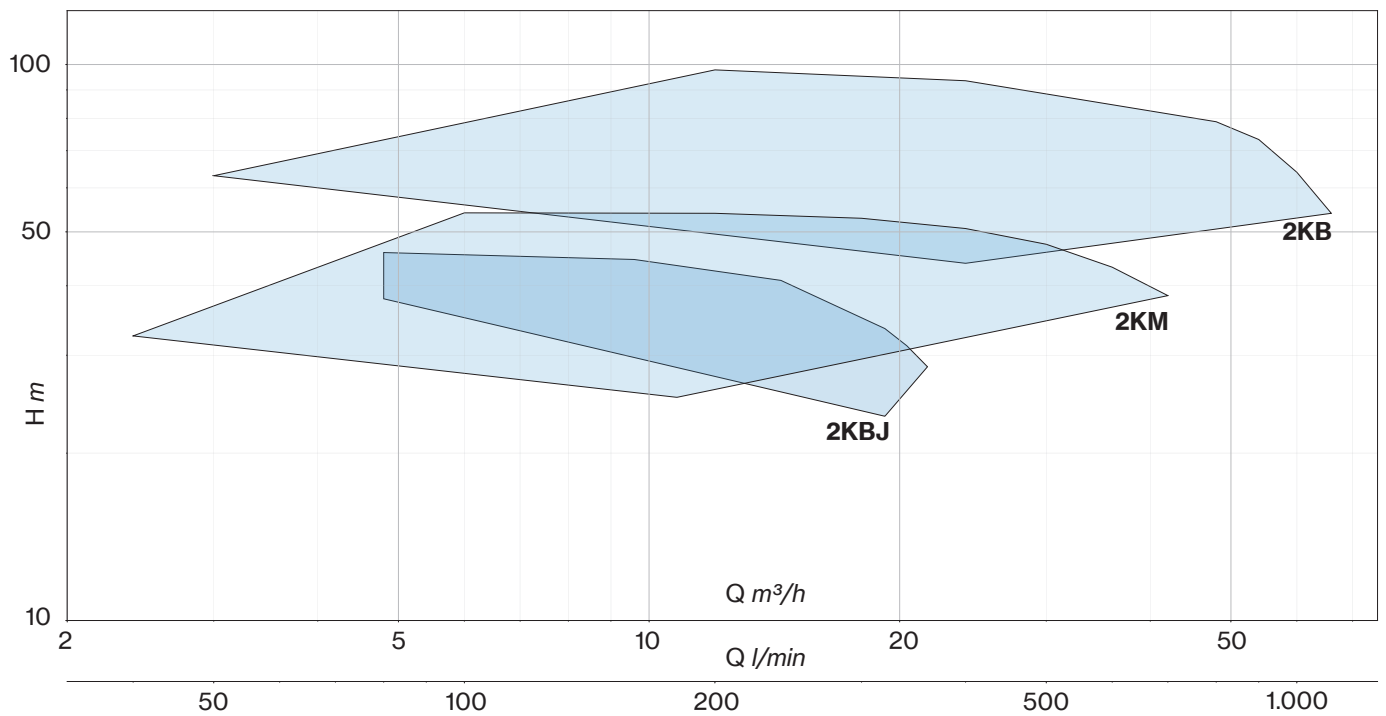

QUICK SELECTION

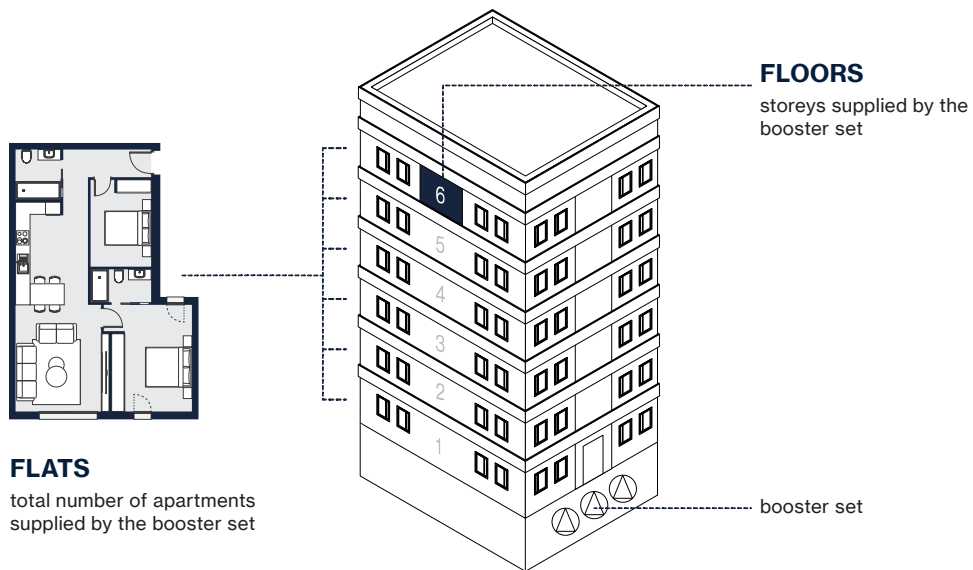

FLATS		FLOORS	KM series	KBJ series	KB series
1 duty and 1 standby pumps	2 duty pumps				
1	2-3	1-2 3	2KM_106_ -	-	- 2KB_100_
2-3	4-6	1-2 3 4-5 6 7	2KM_164_ 2KM_164_ 2KM_214_ 2KM_314_ -	- - - - -	2KB_100_ 2KB_160_ 2KB_160_ 2KB_210_ 2KB_310_
4-5	7-13	1-3 4 5 6	2KM_164_ 2KM_214_ 2KM_214_ 2KM_314_	2KBJ_150_ 2KBJ_200_ 2KBJ_300_ -	2KB_160_ 2KB_160_ 2KB_210_ 2KB_310_
6-8	14-20	1-2 3 4 5	2KM_214_ 2KM_214_ 2KM_214_ 2KM_314_	2KBJ_150_ 2KBJ_200_ 2KBJ_300_ -	2KB_160_ 2KB_160_ 2KB_210_ 2KB_310_
9-14	21-32	1-2 3-4 5-6 7-9 10-12	- - - - -	2KBJ_200_ 2KBJ_300_ - - -	2KB_210_ 2KB_310_ 2KB_400T_ 2KB_550T_ 2KBT_751_
15-28	33-56	1-4 5-6 7-8 9-11 12-13	2KM_400T_ 2KM_400T_ - - -	2KBJ_300_ - - - -	- - 2KB_550T_ 2KB_751RT_ 2KB_900T_

PERFORMANCE

TARGET (2 pumps)		MODEL				P2 NOMINAL		Q (m ³ /h - l/min)															
		FIXED SPEED		VARIABLE SPEED				0	1,2	2,4	3,6	4,8	7,2	9,6	12,0	14,4	16,8	18					
		1- 230V	3- 400V	EPIC	EPIC-A			0	20	40	60	80	120	160	200	240	280	300					
l/min	bar			1- 230V-in 3- 230V-out	3- 400V-in 3- 400V-out	HP (x2)	kW (x2)	H (m)															
60	3,5	2KB100	2KB100T	2KB/E100T	2KB/A100T-304	1	0,74	42,0	40,8	39,4	37,4	34,7	29,2	21,0									
180	4	2KB160	2KB160T	2KB/E160T	2KB/A160T-306	1,5	1,1	53,0	52,5	52,0	51,0	50,0	46,9	43,3	39,7	35,0							
220	4	2KB210	2KB210T	-	2KB/A210T-306	2	1,5	57,3	56,9	56,0	55,1	54,0	51,5	48,4	44,4	39,5	34,0						
220	4,5	2KB310	2KB310T	-	2KB/A310T-306	3	2,2	64,0	63,5	63,0	61,9	60,6	57,7	54,1	50,0	45,4	39,4	36,0					

TARGET (2 pumps)		MODEL				P2 NOMINAL		Q (m ³ /h - l/min)															
		FIXED SPEED		VARIABLE SPEED				0	3	6	9	12	15	18	21	24	27	30	33				
		1- 230V	3- 400V	EPIC	EPIC-A			0	50	100	150	200	250	300	350	400	450	500	550				
l/min	bar			1- 230V-in 3- 230V-out	3- 400V-in 3- 400V-out	HP (x2)	kW (x2)	H (m)															
250	5,5	-	2KB400T	-	2KB/A400T-309	4	3	63,6	63,1	62,0	60,3	58,2	55,5	52,3	48,4	43,9							
300	6,5	-	2KB550T	-	2KB/A550T-314	5,5	4	76,9	76,4	75,4	73,8	71,7	69,0	65,9	62,1	58,0	53,4						
350	7,5	-	2KB751RT	-	2KB/A751RT-314	7,5	5,5	90,7	90,0	88,9	87,3	85,3	82,9	80,1	76,8	73,1	68,8	63,7					
350	8	-	2KB900T	-	2KB/A900T-318	10	7,5	97,5	96,6	95,4	93,7	91,7	89,2	86,5	83,3	79,8	75,2	71,2	66,4				

TARGET (2 pumps)		MODEL				P2 NOMINAL		Q (m ³ /h - l/min)															
		FIXED SPEED		VARIABLE SPEED				0	12	24	36	48	54	60	66								
		1- 230V	3- 400V	EPIC	EPIC-A			0	200	400	600	800	900	1000	1100								
l/min	bar			1- 230V-in 3- 230V-out	3- 400V-in 3- 400V-out	HP (x2)	kW (x2)	H (m)															
600	5	-	2KB750T	-	2KB/A750T-314	7,5	5,5	70,0	68,5	63,9	57,1	45,3	38,2										
800	5,5	-	2KB1000T	-	2KB/A1000T-318	10	7,5	80,7	80,4	75,0	68,5	59,7	52,6	43,7									
900	6	-	2KB1250T	-	2KB/A1250T-318	12,5	9,2	89,5	88,8	84,1	77,7	69,7	63,0	54,2	45,1								
900	7	-	2KB1500T	-	2KB/A1500T-325	15	11	98,3	97,8	93,5	85,7	78,9	73,3	64,0	54,0								

2KB

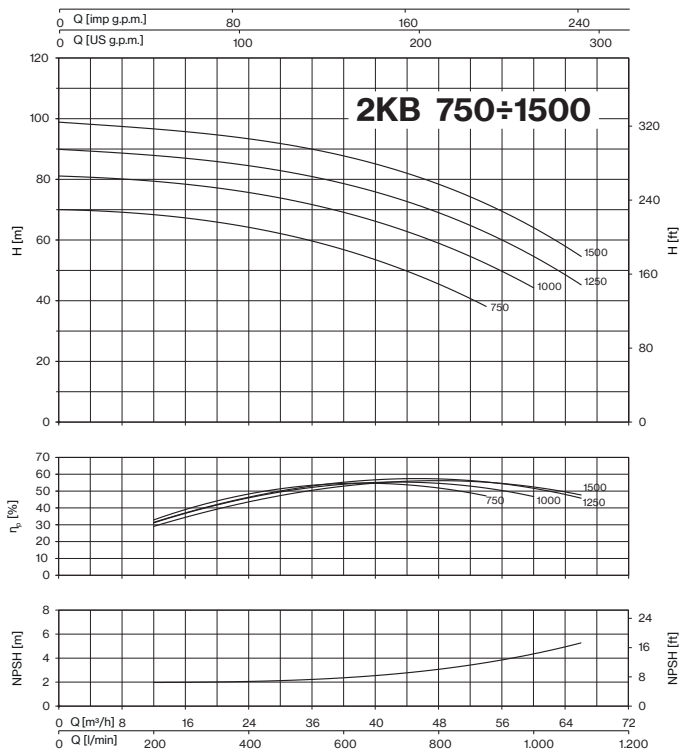
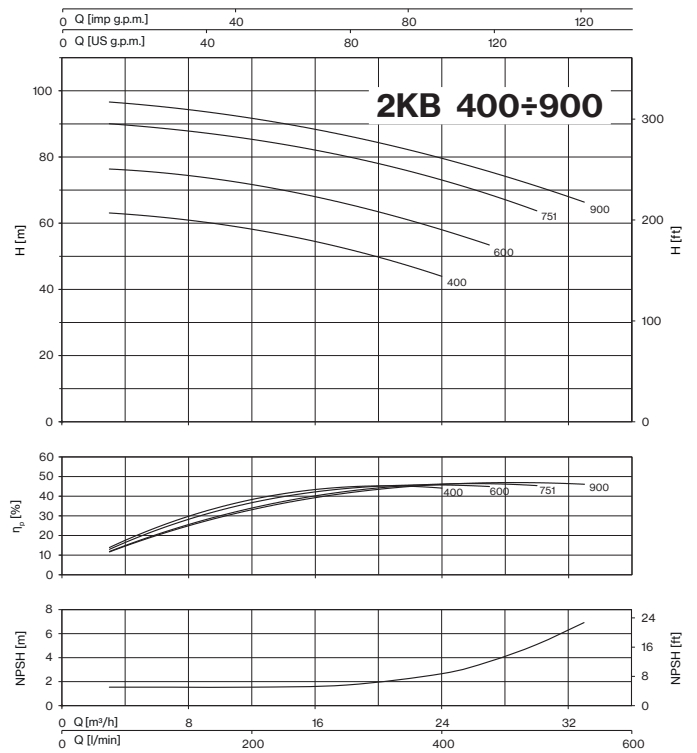
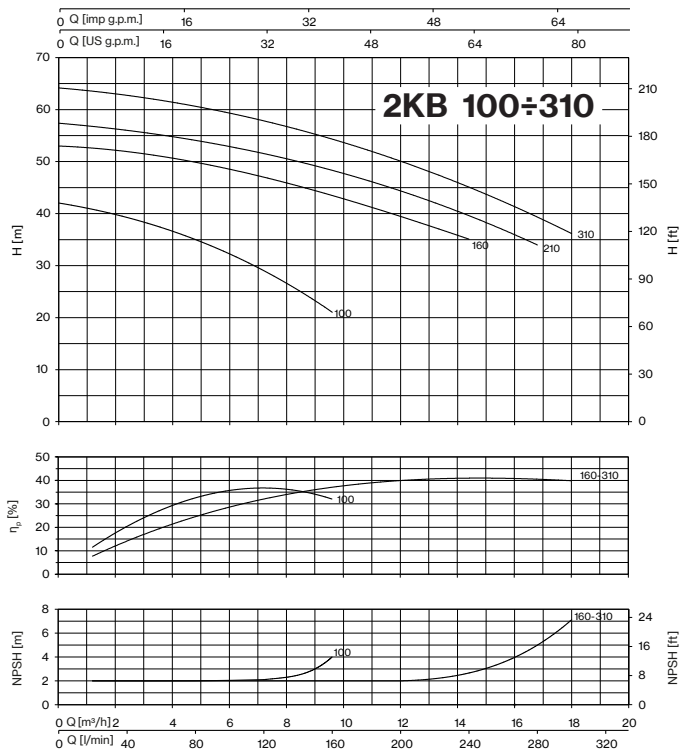

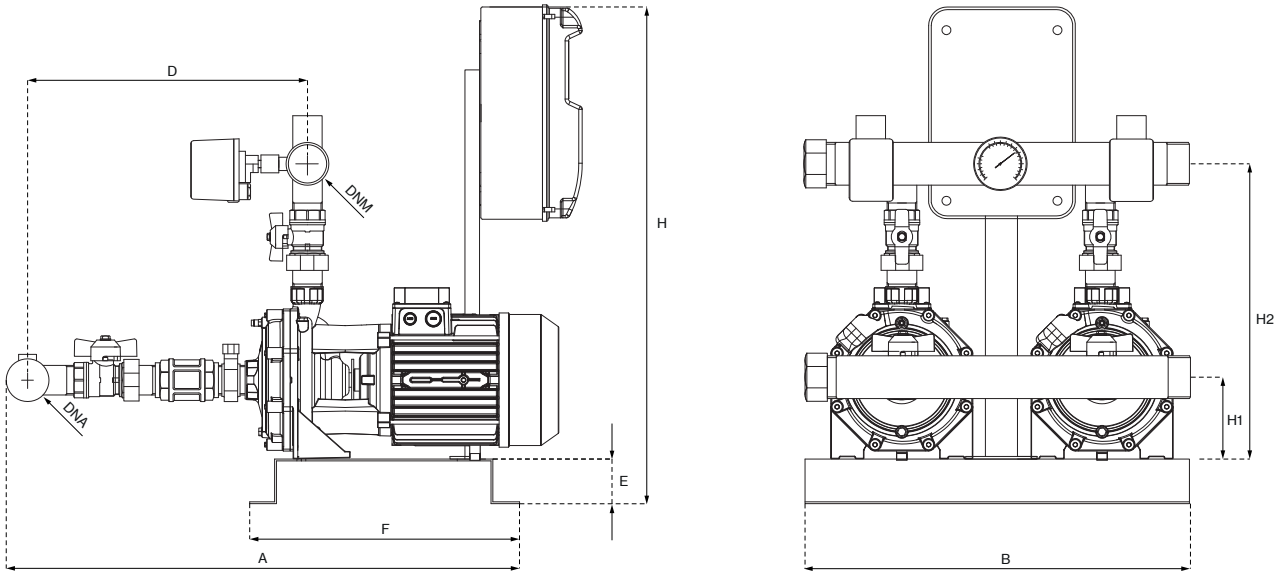

MODEL				P1		In			Required tank for v.s.	DIMENSIONS								WEIGHT			
FIXED SPEED		VARIABLE SPEED		1~	3~	1~ 230V	3~ 400V	3~ 230V		A	B	D	E	F	H	H1	H2	DNA	DNM	f.s.	v.s.
1~	3~	EPIC 1- in 230V 3-out 230V	EPIC-A 3- 400V-in 3- 400V-out	kW (x2)		A (x2)				Lt	mm								Kg		
2KB100	2KB100T	2KB/E100T	2KB/A100T-304	1,17	1,15	5,4	2,4	4,2	2x 8	653	520	351	50	300	633	98	366	2" G	1" 1/2 G	49	54
2KB160	2KB160T	2KB/E160T	2KB/A160T-306	2,3	2,2	10,2	4,1	7,1	2x 20	646	520	361	50	300	633	110	403			65	70
2KB210	2KB210T	-	2KB/A210T-306	2,6	2,45	11,5	4,8	-	2x 20	646	520	361	50	300	633	110	403			66	71
2KB310	2KB310T	-	2KB/A310T-306	2,9	2,8	13,2	5,2	-	2x 20	646	520	361	50	300	633	110	403			67	72
-	2KB400T	-	2KB/A400T-309	-	3,8	-	6,7	-	2x 20	777	615	462	60	380	633	135	464	2" 1/2 G	2" G	108	113
-	2KB550T	-	2KB/A550T-314	-	5	-	9,1	-	1x 50	777	615	462	60	380	633	135	464			116	136
-	2KB751RT	-	2KB/A751RT-314	-	6,5	-	11,5	-	1x 50	777	615	462	60	380	633	135	464			132	152
-	2KB900T	-	2KB/A900T-318	-	7,3	-	13,3	-	1x 50	777	615	462	60	380	633	135	464			144	164
-	2KB750T	-	2KB/A750T-314	-	6,7	-	11,1	-	1x 100	1050	840	470	60	380	920	150	650	DN100	DN80	237	257
-	2KB1000T	-	2KB/A1000T-318	-	8,5	-	13,9	-	1x 100	1050	840	470	60	380	920	150	650			247	267
-	2KB1250T	-	2KB/A1250T-318	-	9,8	-	16,3	-	1x 100	1050	840	470	60	380	920	150	650			264	284
-	2KB1500T	-	2KB/A1500T-325	-	11,2	-	18,6	-	1x 100	1050	900	470	60	380	920	150	650			272	292

f.s. : fixed speed
v.s. : variable speed