

8LR & 8LM lines

Deepwell Borehole

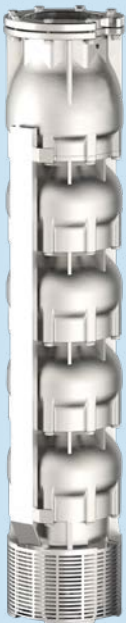

8LR line



8LM line



Submersible multistage centrifugal pumps for 8" wells. Check valve built into the delivery outlet. Pump flange for coupling with motors are made according to NEMA standards. Most common applications are civil and agricultural. All components are made of stainless steel with lost wax Microfusion technology. The standard material is AISI 304 stainless steel, alternatively the following materials are available on request: AISI 316 Steel, Duplex steel, AISI 904L Steel. Bushing bearings and wear-rings made of sand abrasion-resistant rubber, reverse-Thrust ring in PTFE/ Graphite.

General operating data:

- Capacity up to 860 m³/h
- Pressure up to 800 m
- Hydraulic efficiency 8", up to 81,5%
- Pressure up to 80 bar
- Powers up to 400 kW
- Rotation speed up to 3600 rpm
- Maximum depth: 350 m
- Maximum quantity of permitted sand: 100 gr/m³
- Drinking water compatibility according to DM174 MEI >= 0,4 (EU directive No.547/2012)
- Performance tolerance: ISO9906-3B.

Construction features

Suction and delivery outlet	stainless steel AISI 304 (LRS-LMS) stainless steel AISI 316 (LRX-LMX) Duplex (LRD-LMD)
Valve	stainless steel AISI 304 (LRS-LMS) stainless steel AISI 316 (LRX-LMX) Duplex (LRD-LMD)
Impellers and diffusers	stainless steel AISI 304 (LRS-LMS) stainless steel AISI 316 (LRX-LMX) Duplex (LRD-LMD)
Upper bushings	NBR rubber
Shaft pump side	stainless steel AISI 304 (LRS-LMS) stainless steel AISI 316 (LRX-LMX) Duplex (LRD-LMD)
Quantity of sand in the water	max 100 gr/m ³



8LR 34

Motor 50 Hz - 2900 rpm				Q									
TYPE	Power		400 V	l/min l/sec m ³ /h	0	150	200	300	400	500	600	700	750
	HP	kW			A	0	2,5	3,3	5,0	6,7	8,3	10,0	11,7
			0	9		12	18	24	30	36	42	45	
8LR 34/01	4	3	7,5	H[m]	23	22	21	20	20	18	17	14	13
8LR 34/02	7,5	5,5	12,5		46	45	42	41	39	37	33	28	25
8LR 34/03	10	7,5	16,3		69	67	64	61	59	55	50	41	38
8LR 34/04	15	11	23,4		92	90	85	82	78	73	66	55	51
8LR 34/05	17,5	13	27,3		115	112	106	102	98	92	83	69	64
8LR 34/06	20	15	31,5		138	134	127	122	117	110	99	83	76
8LR 34/07	25	18,5	38,3		161	157	148	143	137	128	116	97	89
8LR 34/08	30	22	45,1		184	179	170	163	156	146	132	110	102
8LR 34/09	30	22	45,1		207	202	191	184	176	165	149	124	114
8LR 34/10	35	26	52,9		230	224	212	204	195	183	165	138	127
8LR 34/11	40	30	61,1		253	246	233	224	215	201	182	152	140
8LR 34/12	40	30	61,1		276	269	254	245	234	220	198	166	152
8LR 34/13	50	37	75,8		299	291	276	265	254	238	215	179	165
8LR 34/14	50	37	75,8		322	314	297	286	273	256	231	193	178
8LR 34/15	50	37	75,8		345	336	318	306	293	275	248	207	191
8LR 34/16	60	45	86,3		368	358	339	326	312	293	264	221	203
8LR 34/17	60	45	86,3		391	381	360	347	332	311	281	235	216
8LR 34/18	60	45	86,3		414	403	382	367	351	329	297	248	229
8LR 34/19	75	55	106,2		437	426	403	388	371	348	314	262	241

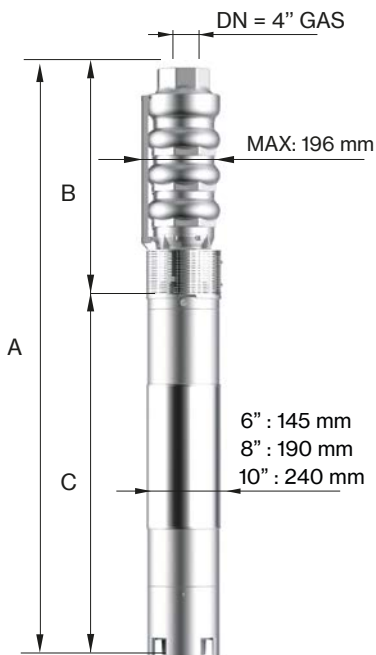

Motor 50 Hz 2900 rpm	DIMENSIONS (mm)			Weight (kg)	
TYPE	A	B	C	M	P
8LR 34/01	917	360	557	19	15
8LR 34/02	1138	440	698	27	21
8LR 34/03	1221	520	701	55	27
8LR 34/04	1411	600	811	65	33
8LR 34/05	1521	680	841	70	40
8LR 34/06	1691	760	931	75	46
8LR 34/07	1831	840	991	83	52
8LR 34/08	1991	920	1071	92	58
8LR 34/09	2071	1000	1071	92	64
8LR 34/10	2261	1080	1181	100	70
8LR 34/11	2411	1160	1251	108	76
8LR 34/12	2491	1240	1251	108	82
8LR 34/13	2661	1320	1341	118	88
8LR 34/14	2771	1430	1341	118	95
8LR 34/15	2851	1510	1341	118	101
8LR 34/16	2713	1590	1123	178	107
8LR 34/17	2793	1670	1123	178	113
8LR 34/18	2873	1750	1123	178	119
8LR 34/19	3063	1830	1233	200	125

Max Eff. % =	73,5
Max kW / St. =	2,4

Q (flow)	25%	50%	75%	100%
NPSH (m)	3	3	4,5	6,7

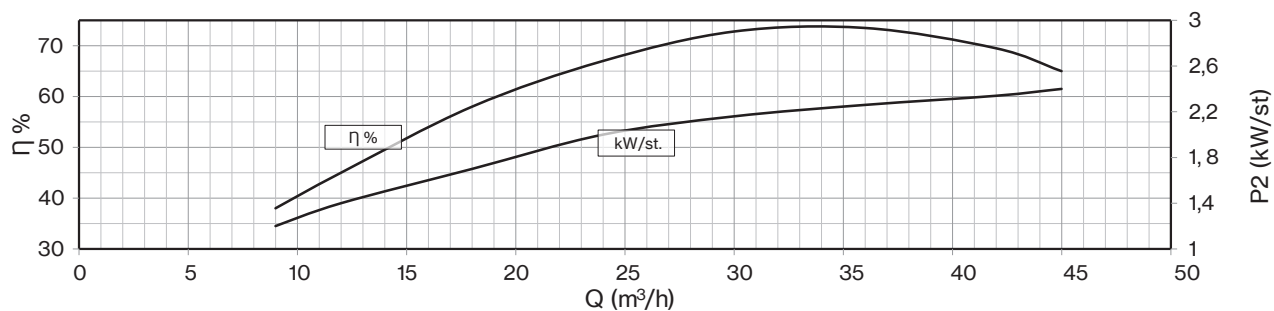
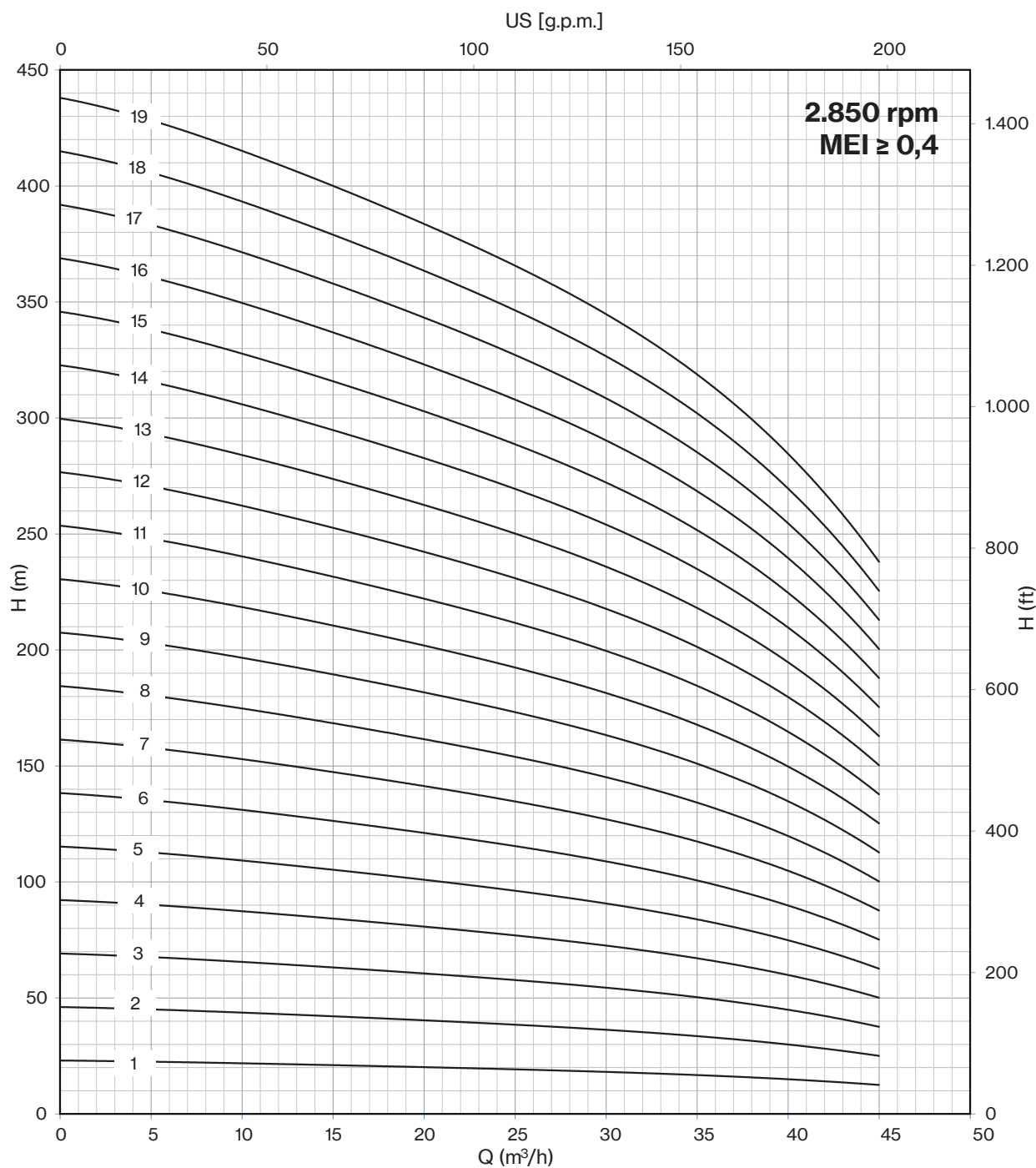

8LR 34

Motor 50 Hz - 2900 rpm				Q									
TYPE	Power		400 V	I/min	0	150	200	300	400	500	600	700	750
	HP	kW		A	I/sec	0	2,5	3,3	5,0	6,7	8,3	10,0	11,7
			m ³ /h		0	9	12	18	24	30	36	42	45
8LR 34/20*	75	55	106,2	H[m]	460	448	424	408	390	366	330	276	254
8LR 34/21*	75	55	106,2		483	470	445	428	410	384	347	290	267
8LR 34/22*	75	55	106,2		506	493	466	449	429	403	363	304	279
8LR 34/23*	90	66	126,0		529	515	488	469	449	421	380	317	292
8LR 34/24*	90	66	126,0		552	538	509	490	468	439	396	331	305
8LR 34/25*	90	66	126,0		575	560	530	510	488	458	413	345	318
8LR 34/26*	90	66	126,0		598	582	551	530	507	476	429	359	330
8LR 34/27*	90	66	126,0		621	605	572	551	527	494	446	373	343
8LR 34/28*	100	75	143,2		644	627	594	571	546	512	462	386	356
8LR 34/29*	100	75	143,2		667	650	615	592	566	531	479	400	368
8LR 34/30*	100	75	143,2		690	672	636	612	585	549	495	414	381
8LR 34/31*	100	75	143,2		713	694	657	632	605	567	512	428	394
8LR 34/32*	125	92	175,1		736	717	678	653	624	586	528	442	406
8LR 34/33*	125	92	175,1		759	739	700	673	644	604	545	455	419

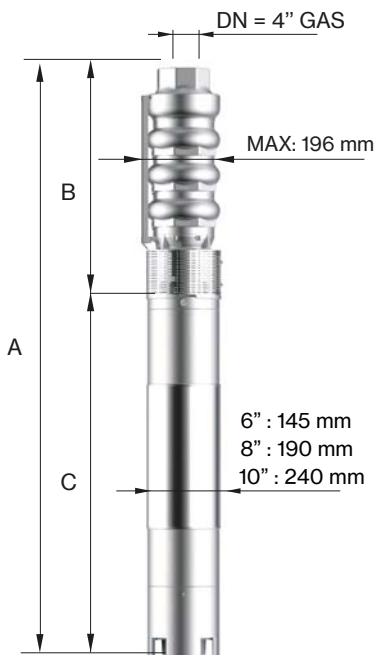

Motor 50 Hz 2900 rpm	DIMENSIONS (mm)			Weight (kg)	
TYPE	A	B	C	M	P
8LR 34/20*	3143	1910	1233	200	132
8LR 34/21*	3223	1990	1233	200	138
8LR 34/22*	3303	2070	1233	200	144
8LR 34/23*	3582	2280	1302	214	155
8LR 34/24*	3662	2360	1302	214	161
8LR 34/25*	3742	2440	1302	214	167
8LR 34/26*	3822	2520	1302	214	173
8LR 34/27*	3902	2600	1302	214	179
8LR 34/28*	4063	2680	1383	230	185
8LR 34/29*	4143	2760	1383	230	191
8LR 34/30*	4223	2840	1383	230	198
8LR 34/31*	4303	2920	1383	230	204
8LR 34/32*	4583	3000	1583	270	210
8LR 34/33*	4663	3080	1583	270	216

Max Eff. % =	73,5
Max kW / St. =	2,4

Q (flow)	25%	50%	75%	100%
NPSH (m)	3	3	4,5	6,7

* Coupled pump shaft

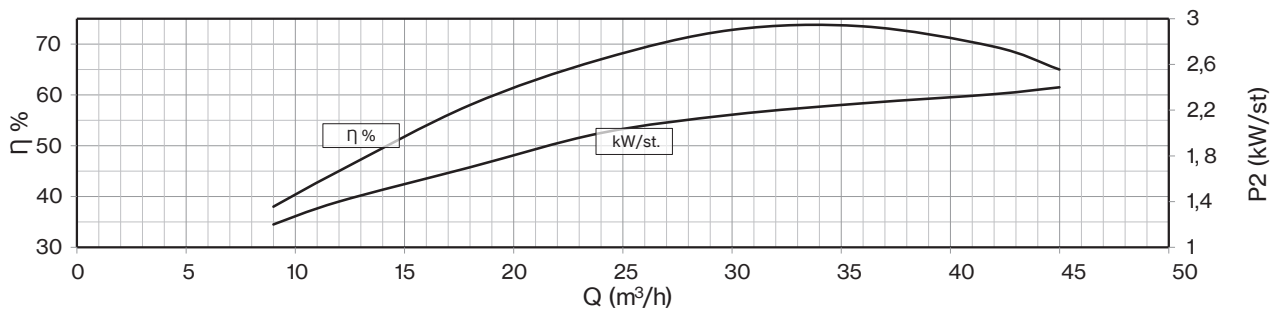
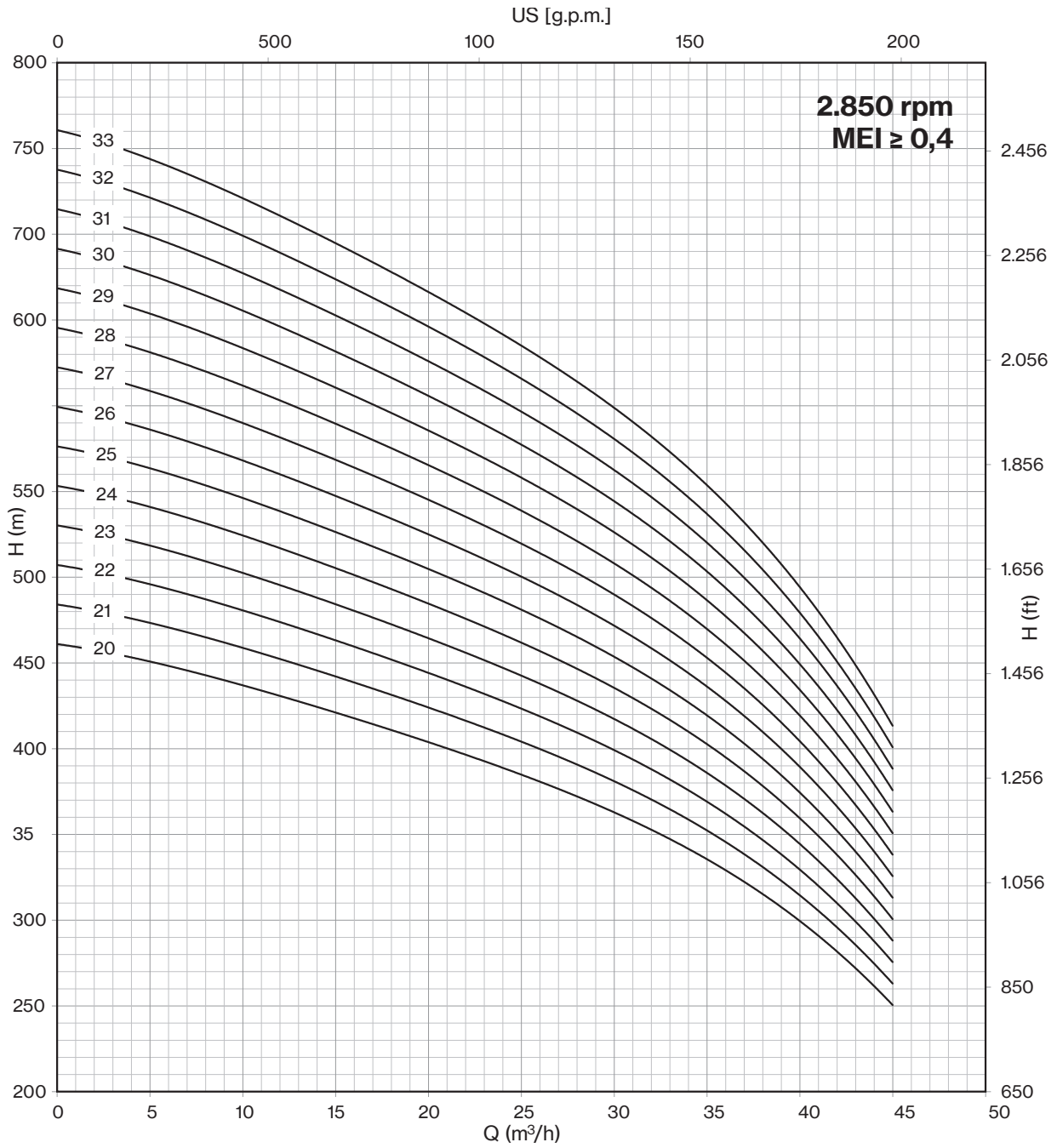

8LR 42

Motor 50 Hz - 2900 rpm				Q									
TYPE	Power		400 V	l/min l/sec m ³ /h	0	200	300	400	500	600	700	800	900
	HP	kW			A	0	3,3	5,0	6,7	8,3	10,0	11,7	13,3
					0	12	18	24	30	36	42	48	54
8LR 42/01	4	3	7,5	H[m]	24	23	22	21	20	18	16	14	11
8LR 42/02	10	7,5	16,3		48	46	43	42	39	36	32	28	21
8LR 42/03	12,5	9,2	19,9		72	68	65	62	59	55	49	41	32
8LR 42/04	17,5	13	27,3		96	91	86	83	78	73	65	55	42
8LR 42/05	20	15	31,5		120	114	108	104	98	91	81	69	53
8LR 42/06	25	18,5	38,3		144	137	130	125	118	109	97	83	64
8LR 42/07	30	22	45,1		168	160	151	146	137	127	113	97	74
8LR 42/08	35	26	52,9		192	182	173	166	157	146	130	110	85
8LR 42/09	35	26	52,9		216	205	194	187	176	164	146	124	95
8LR 42/10	40	30	61,1		240	228	216	208	196	182	162	138	106
8LR 42/11	50	37	75,8		264	251	238	229	216	200	178	152	117
8LR 42/12	50	37	75,8		288	274	259	250	235	218	194	166	127
8LR 42/13	50	37	75,8		312	296	281	270	255	237	211	179	138
8LR 42/14	60	45	86,3		336	319	302	291	274	255	227	193	148
8LR 42/15	60	45	86,3		360	342	324	312	294	273	243	207	159
8LR 42/16	60	45	86,3		384	365	346	333	314	291	259	221	170

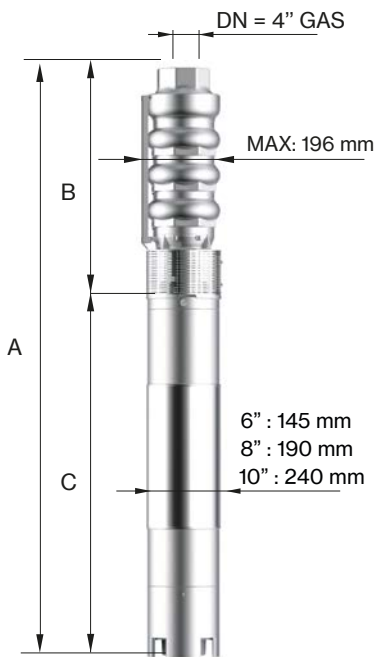

Motor 50 Hz 2900 rpm	DIMENSIONS (mm)			Weight (kg)	
	TYPE	A	B	C	M
8LR 42/01	917	360	557	19	15
8LR 42/02	1141	440	701	55	21
8LR 42/03	1271	520	751	60	27
8LR 42/04	1441	600	841	70	33
8LR 42/05	1611	680	931	75	40
8LR 42/06	1751	760	991	83	46
8LR 42/07	1911	840	1071	92	52
8LR 42/08	2101	920	1181	100	58
8LR 42/09	2181	1000	1181	100	64
8LR 42/10	2331	1080	1251	108	70
8LR 42/11	2501	1160	1341	118	76
8LR 42/12	2581	1240	1341	118	82
8LR 42/13	2661	1320	1341	118	88
8LR 42/14	2553	1430	1123	178	95
8LR 42/15	2633	1510	1123	178	101
8LR 42/16	2713	1590	1123	178	107

Max Eff. % =	73
Max kW / St. =	2,8

Q (flow)	25%	50%	75%	100%
NPSH (m)	3,4	3,4	3,8	8

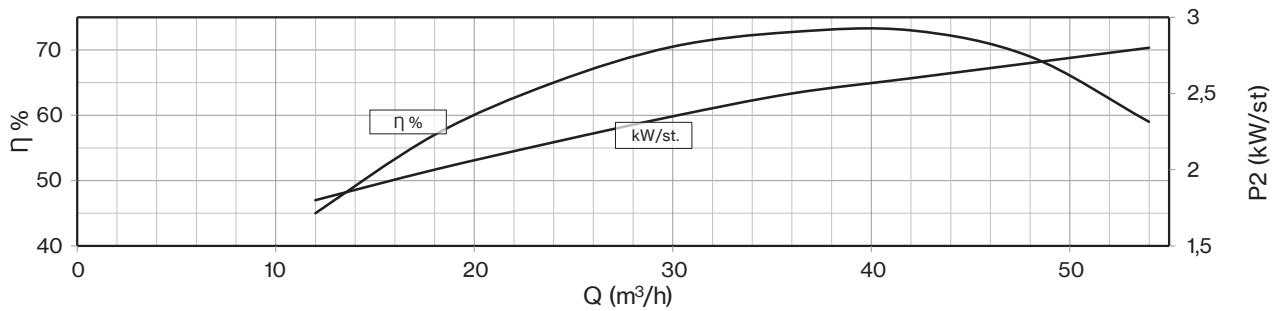
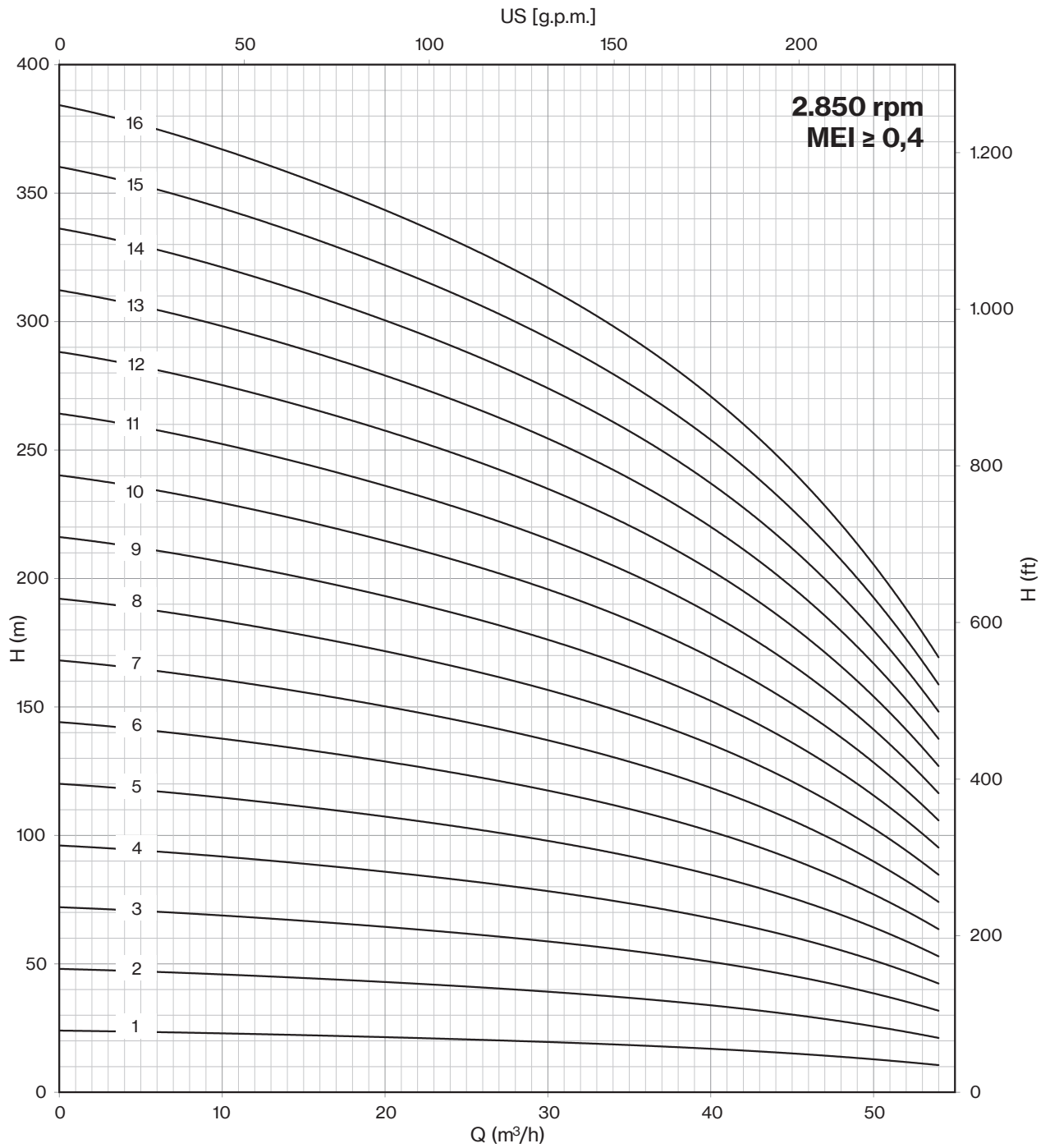

8LR 42

Motor 50 Hz - 2900 rpm				Q									
TYPE	Power		400 V	l/min l/sec m ³ /h	0	200	300	400	500	600	700	800	900
	HP	kW			A	0	3,3	5,0	6,7	8,3	10,0	11,7	13,3
				H[m]	0	12	18	24	30	36	42	48	54
8LR 42/17	75	55	106,2		408	388	367	354	333	309	275	235	180
8LR 42/18	75	55	106,2		432	410	389	374	353	328	292	248	191
8LR 42/19	75	55	106,2		456	433	410	395	372	346	308	262	201
8LR 42/20*	90	66	126,0		480	456	432	416	392	364	324	276	212
8LR 42/21*	90	66	126,0		504	479	454	437	412	382	340	290	223
8LR 42/22*	90	66	126,0		528	502	475	458	431	400	356	304	233
8LR 42/23*	90	66	126,0		552	524	497	478	451	419	373	317	244
8LR 42/24*	100	75	143,2		576	547	518	499	470	437	389	331	254
8LR 42/25*	100	75	143,2		600	570	540	520	490	455	405	345	265
8LR 42/26*	100	75	143,2		624	593	562	541	510	473	421	359	276
8LR 42/27*	125	92	175,1		648	616	583	562	529	491	437	373	286
8LR 42/28*	125	92	175,1		672	638	605	582	549	510	454	386	297
8LR 42/29*	125	92	175,1		696	661	626	603	568	528	470	400	307
8LR 42/30*	125	92	175,1		720	684	648	624	588	546	486	414	318
8LR 42/31*	125	92	175,1		744	707	670	645	608	564	502	428	329
8LR 42/32*	125	92	175,1		768	730	691	666	627	582	518	442	339

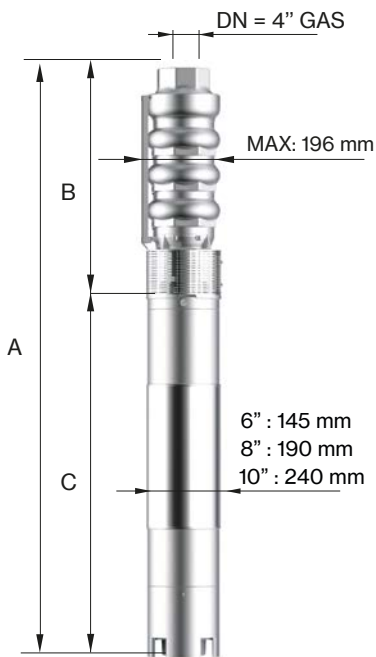

Motor 50 Hz 2900 rpm	DIMENSIONS (mm)			Weight (kg)	
	TYPE	A	B	C	M
8LR 42/17	2903	1670	1233	200	113
8LR 42/18	2983	1750	1233	200	119
8LR 42/19	3063	1830	1233	200	125
8LR 42/20*	3342	2040	1302	214	137
8LR 42/21*	3422	2120	1302	214	143
8LR 42/22*	3502	2200	1302	214	149
8LR 42/23*	3582	2280	1302	214	155
8LR 42/24*	3743	2360	1383	230	161
8LR 42/25*	3823	2440	1383	230	167
8LR 42/26*	3903	2520	1383	230	173
8LR 42/27*	4183	2600	1583	270	179
8LR 42/28*	4263	2680	1583	270	185
8LR 42/29*	4343	2760	1583	270	191
8LR 42/30*	4423	2840	1583	270	198
8LR 42/31*	4503	2920	1583	270	204
8LR 42/32*	4583	3000	1583	270	210

Max Eff. % =	73
Max kW / St. =	2,8

Q (flow)	25%	50%	75%	100%
NPSH (m)	3,4	3,4	3,8	8

* Coupled pump shaft

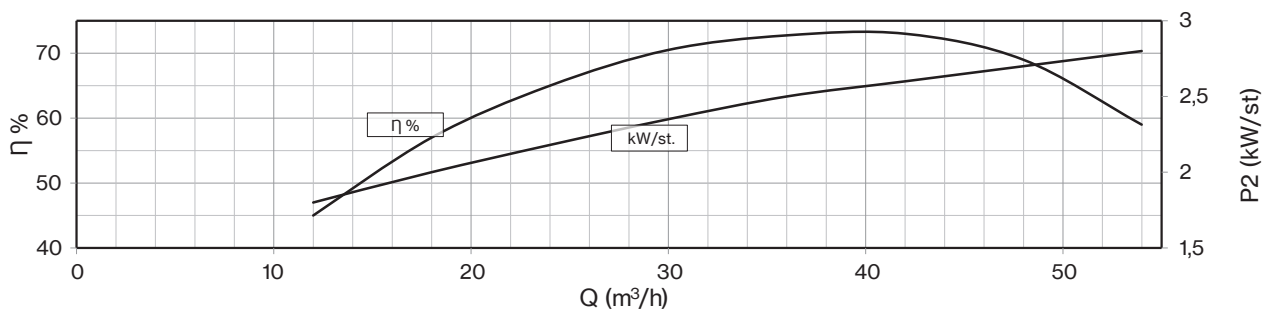
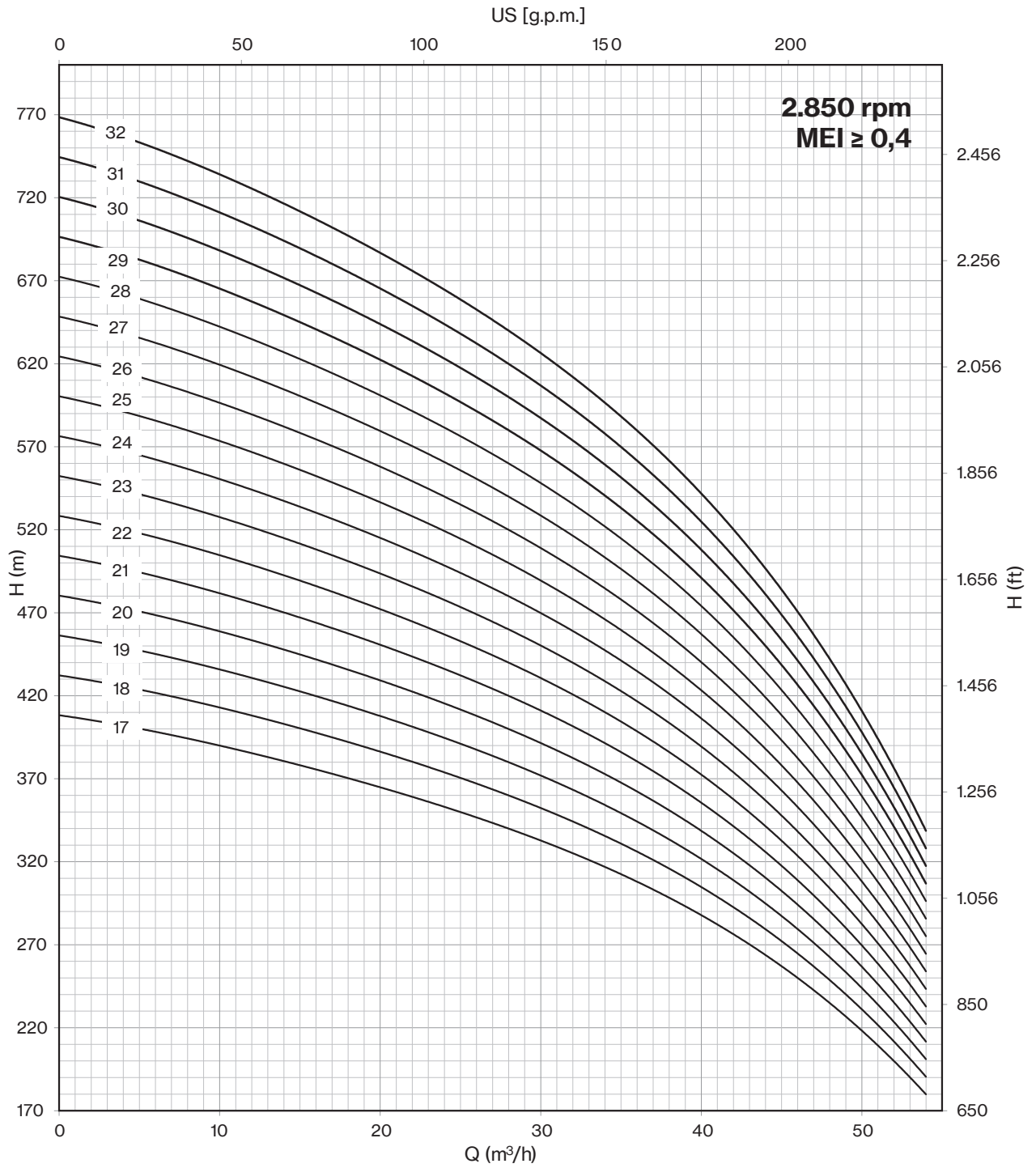

8LR 52

Motor 50 Hz - 2900 rpm				Q									
TYPE	Power		400 V	l/min l/sec m ³ /h	0	300	500	600	700	800	900	1000	1100
	HP	kW			A	0	5,0	8,3	10,0	11,7	13,3	15,0	16,7
					0	18	30	36	42	48	54	60	66
8LR 52/01	5,5	4	10,0	H[m]	24	23	22	20	19	18	16	15	13
8LR 52/02	10	7,5	16,3		48	46	43	41	39	36	33	29	26
8LR 52/03	15	11	23,4		72	68	65	61	58	53	49	44	38
8LR 52/04	20	15	31,5		96	91	86	81	77	71	65	58	51
8LR 52/05	25	18,5	38,3		120	114	108	102	97	89	82	73	64
8LR 52/06	30	22	45,1		144	137	129	122	116	107	98	87	77
8LR 52/07	35	26	52,9		168	159	151	142	135	125	114	102	90
8LR 52/08	40	30	61,1		192	182	172	162	154	142	130	116	102
8LR 52/09	50	37	75,8		216	205	194	183	174	160	147	131	115
8LR 52/10	50	37	75,8		240	228	215	203	193	178	163	145	128
8LR 52/11	60	45	86,3		264	251	237	223	212	196	179	160	141
8LR 52/12	60	45	86,3		288	273	258	244	232	214	196	174	154
8LR 52/13	60	45	86,3		312	296	280	264	251	231	212	189	166
8LR 52/14	75	55	106,2		336	319	301	284	270	249	228	203	179
8LR 52/15	75	55	106,2		360	342	323	305	290	267	245	218	192
8LR 52/16	75	55	106,2		384	364	344	325	309	285	261	232	205

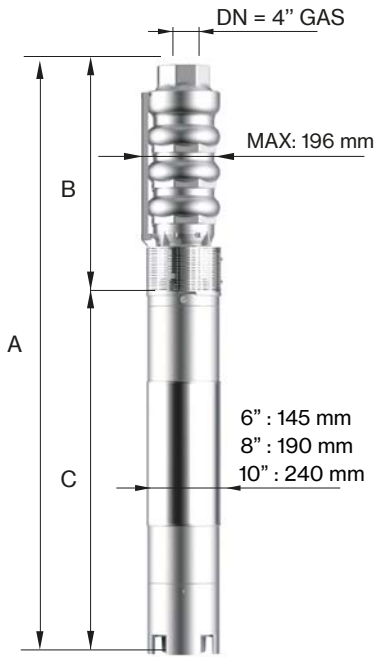

Motor 50 Hz 2900 rpm	DIMENSIONS (mm)			Weight (kg)	
TYPE	A	B	C	M	P
8LR 52/01	965	368	597	22	16
8LR 52/02	1157	456	701	55	22
8LR 52/03	1355	544	811	65	29
8LR 52/04	1563	632	931	75	35
8LR 52/05	1711	720	991	83	42
8LR 52/06	1879	808	1071	92	48
8LR 52/07	2077	896	1181	100	55
8LR 52/08	2235	984	1251	108	61
8LR 52/09	2413	1072	1341	118	68
8LR 52/10	2501	1160	1341	118	74
8LR 52/11	2401	1278	1123	178	81
8LR 52/12	2489	1366	1123	178	88
8LR 52/13	2577	1454	1123	178	94
8LR 52/14	2775	1542	1233	200	101
8LR 52/15	2863	1630	1233	200	107
8LR 52/16	2951	1718	1233	200	114

Max Eff. % =	73
Max kW / St. =	3,4

Q (flow)	25%	50%	75%	100%
NPSH (m)	3,5	3,5	6	8

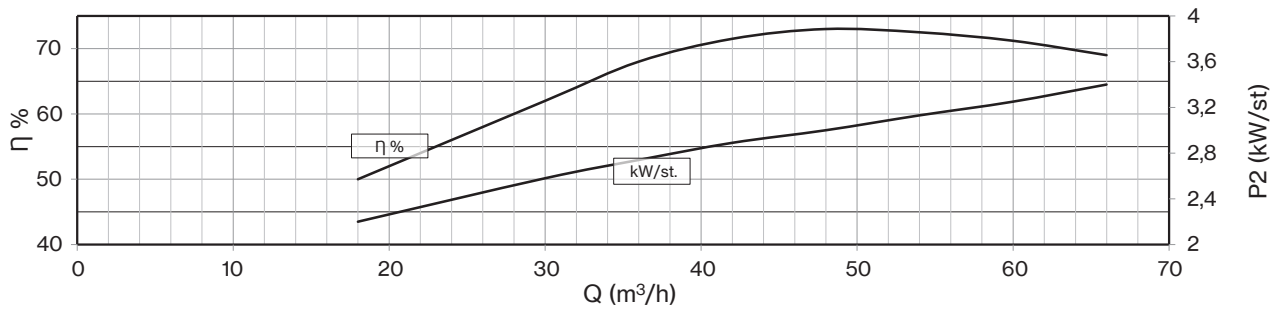
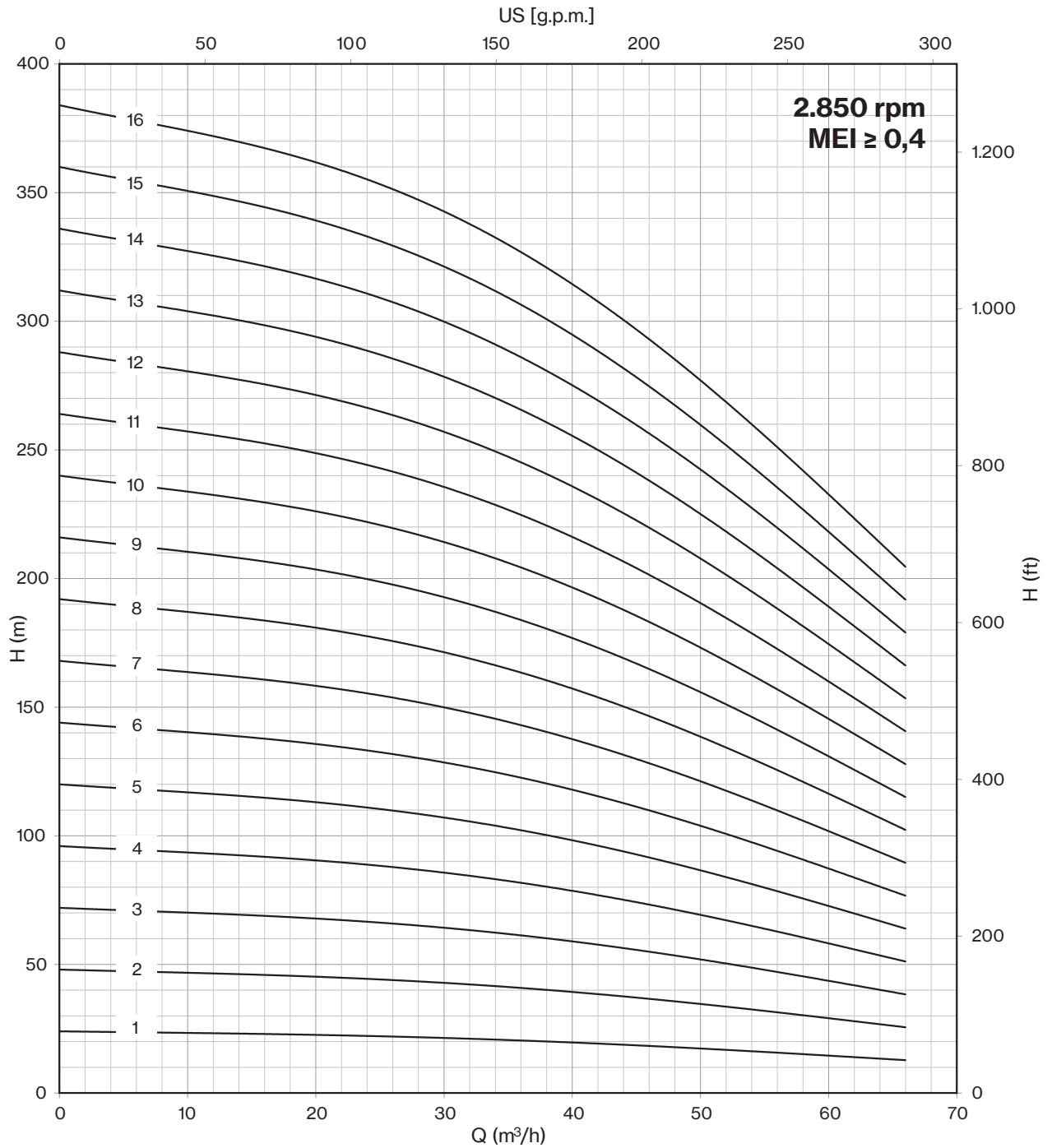

8LR 52

Motor 50 Hz - 2900 rpm				Q									
TYPE	Power		400 V	l/min l/sec m3/h	0	300	500	600	700	800	900	1000	1100
	HP	kW			A	0	5,0	8,3	10,0	11,7	13,3	15,0	16,7
			0	18		30	36	42	48	54	60	66	
8LR 52/17	90	66	126,0	H[m]	408	387	366	345	328	303	277	247	218
8LR 52/18	90	66	126,0		432	410	387	365	347	320	293	261	230
8LR 52/19	90	66	126,0		456	433	409	386	367	338	310	276	243
8LR 52/20*	100	75	143,2		480	456	430	406	386	356	326	290	256
8LR 52/21*	100	75	143,2		504	478	452	426	405	374	342	305	269
8LR 52/22*	100	75	143,2		528	501	473	447	425	392	359	319	282
8LR 52/23*	125	92	175,1		552	524	495	467	444	409	375	334	294
8LR 52/24*	125	92	175,1		576	547	516	487	463	427	391	348	307
8LR 52/25*	125	92	175,1		600	570	538	508	483	445	408	363	320
8LR 52/26*	125	92	175,1		624	592	559	528	502	463	424	377	333
8LR 52/27*	125	92	175,1		648	615	581	548	521	481	440	392	346
8LR 52/28 D*	150	110	219,0		672	638	602	568	540	498	456	406	358
8LR 52/29 D*	150	110	211,0		696	661	624	589	560	516	473	421	371
8LR 52/30 D*	150	110	211,0		720	683	645	609	579	534	489	435	384
8LR 52/31 D*	150	110	211,0		744	706	667	629	598	552	505	450	397
8LR 52/32 D*	150	110	211,0		768	729	688	650	618	570	522	464	410

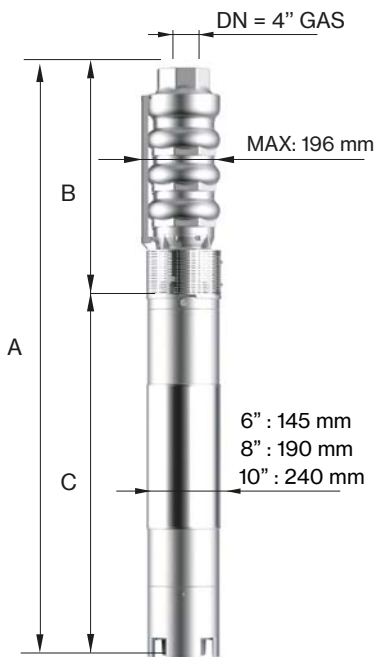

Motor 50 Hz 2900 rpm	DIMENSIONS (mm)			Weight (kg)	
	TYPE	A	B	C	M
8LR 52/17	3108	1806	1302	214	120
8LR 52/18	3196	1894	1302	214	127
8LR 52/19	3284	1982	1302	214	133
8LR 52/20*	3583	2200	1383	230	145
8LR 52/21*	3671	2288	1383	230	151
8LR 52/22*	3759	2376	1383	230	158
8LR 52/23*	4047	2464	1583	270	164
8LR 52/24*	4135	2552	1583	270	171
8LR 52/25*	4223	2640	1583	270	177
8LR 52/26*	4311	2728	1583	270	184
8LR 52/27*	4399	2816	1583	270	190
8LR 52/28 D*	4824	2904	1920	350	197
8LR 52/29 D*	4725	2992	1733	300	203
8LR 52/30 D*	4813	3080	1733	300	210
8LR 52/31 D*	4901	3168	1733	300	216
8LR 52/32 D*	4989	3256	1733	300	223

Max Eff. % =	73
Max kW / St. =	3,4

Q (flow)	25%	50%	75%	100%
NPSH (m)	3,5	3,5	6	8

* Coupled pump shaft
"D" Pump shaft in Duplex

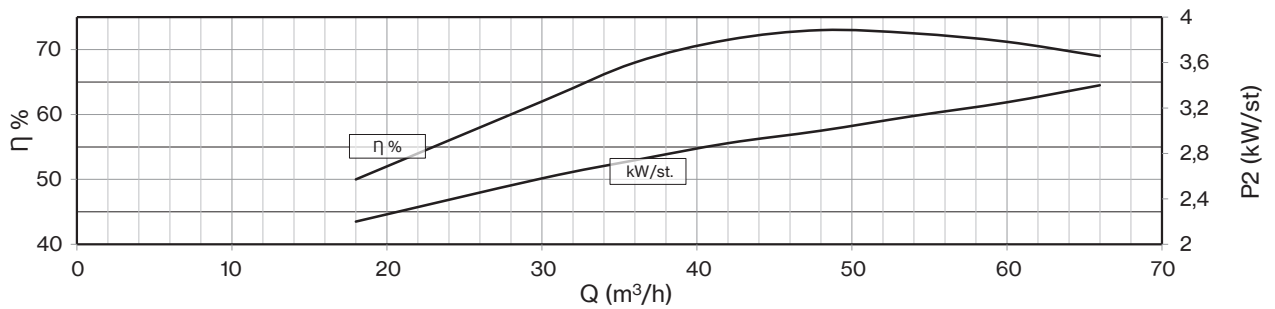
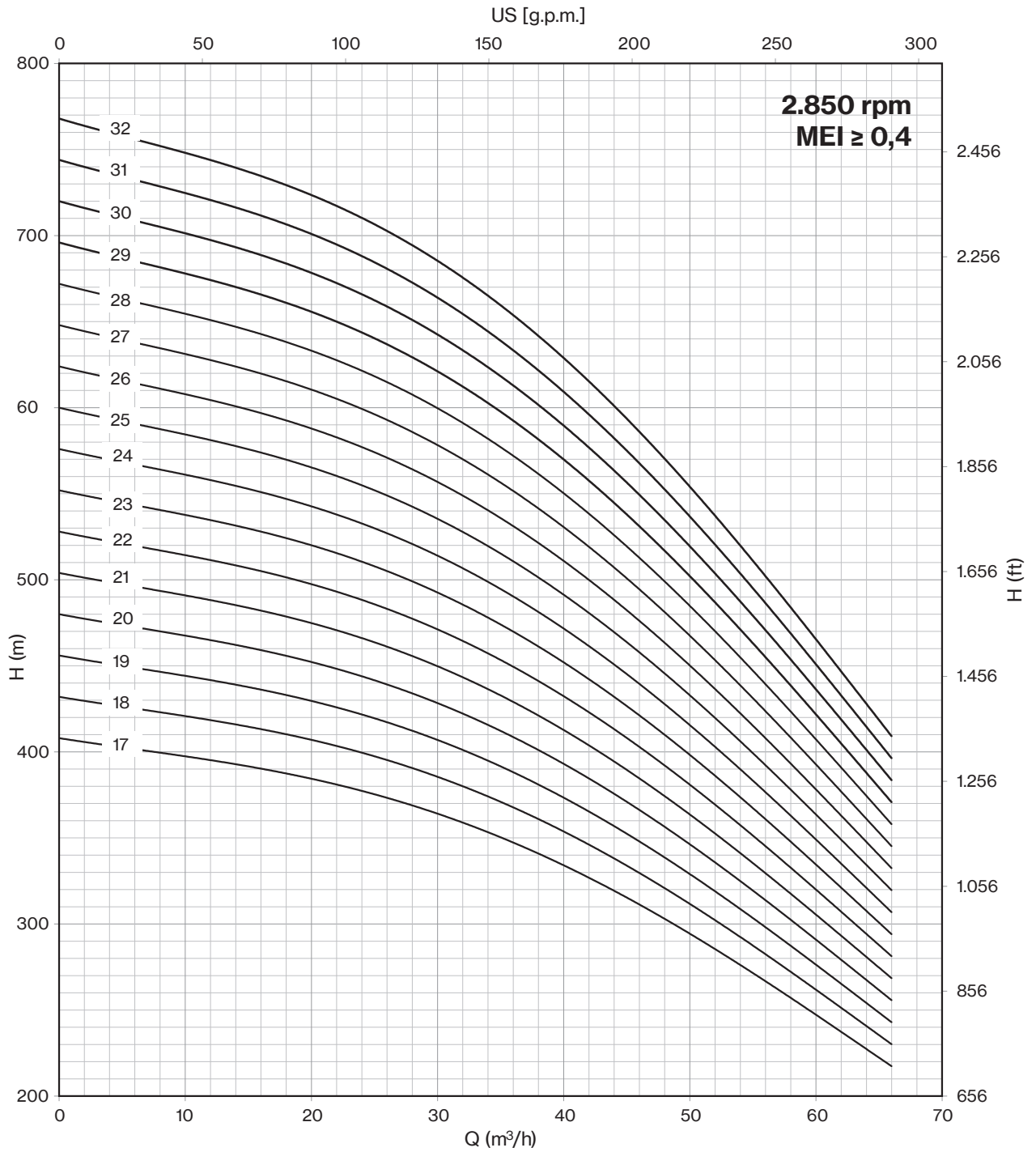

8LR 62

Motor 50 Hz - 2900 rpm				Q									
TYPE	Power		400 V	0	300	600	800	900	1000	1100	1200	1300	
	HP	kW	A	l/min	5,0	10,0	13,3	15,0	16,7	18,3	20,0	21,7	
				l/sec	0	18	36	48	54	60	66	72	78
				m ³ /h	0	18	36	48	54	60	66	72	78
8LR 62/01	5,5	4	10,0	H[m]	23	22	20	18	17	15	14	12	11
8LR 62/02	12,5	9,2	19,9		46	43	40	36	33	30	27	24	21
8LR 62/03	17,5	13	27,3		69	65	60	54	50	45	41	36	32
8LR 62/04	25	18,5	38,3		92	86	80	72	66	60	54	48	42
8LR 62/05	30	22	45,1		115	108	100	90	83	75	68	60	53
8LR 62/06	35	26	52,9		138	129	120	108	99	90	81	72	63
8LR 62/07	40	30	61,1		161	151	140	126	116	105	95	84	74
8LR 62/08	50	37	75,8		184	172	160	144	132	120	108	96	84
8LR 62/09	50	37	75,8		207	194	180	162	149	135	122	108	95
8LR 62/10	60	45	86,3		230	215	200	180	165	150	135	120	105
8LR 62/11	60	45	86,3		253	237	220	198	182	165	149	132	116
8LR 62/12	75	55	106,2		276	258	240	216	198	180	162	144	126
8LR 62/13	75	55	106,2		299	280	260	234	215	195	176	156	137
8LR 62/14	75	55	106,2		322	301	280	252	231	210	189	168	147
8LR 62/15	90	66	126,0		345	323	300	270	248	225	203	180	158

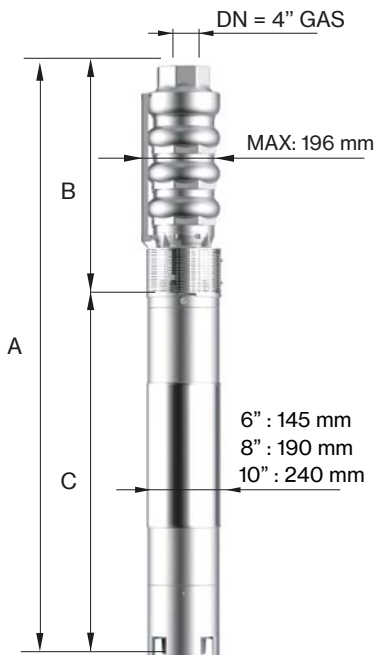

TYPE	DIMENSIONS (mm)			Weight (kg)	
	A	B	C	M	P
8LR 62/01	965	368	597	22	16
8LR 62/02	1207	456	751	60	22
8LR 62/03	1385	544	841	70	29
8LR 62/04	1623	632	991	83	35
8LR 62/05	1791	720	1071	92	42
8LR 62/06	1989	808	1181	100	48
8LR 62/07	2147	896	1251	108	55
8LR 62/08	2325	984	1341	118	61
8LR 62/09	2413	1072	1341	118	68
8LR 62/10	2283	1160	1123	178	74
8LR 62/11	2401	1278	1123	178	81
8LR 62/12	2599	1366	1233	200	88
8LR 62/13	2687	1454	1233	200	94
8LR 62/14	2775	1542	1233	200	101
8LR 62/15	2932	1630	1302	214	107

Max Eff. % =	74,5
Max kW / St. =	3,8

Q (flow)	25%	50%	75%	100%
NPSH (m)	3,4	3,4	6	8

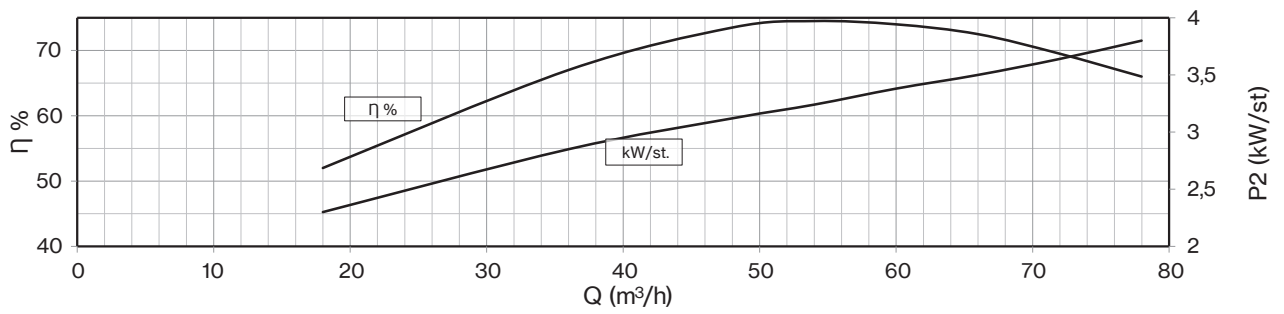
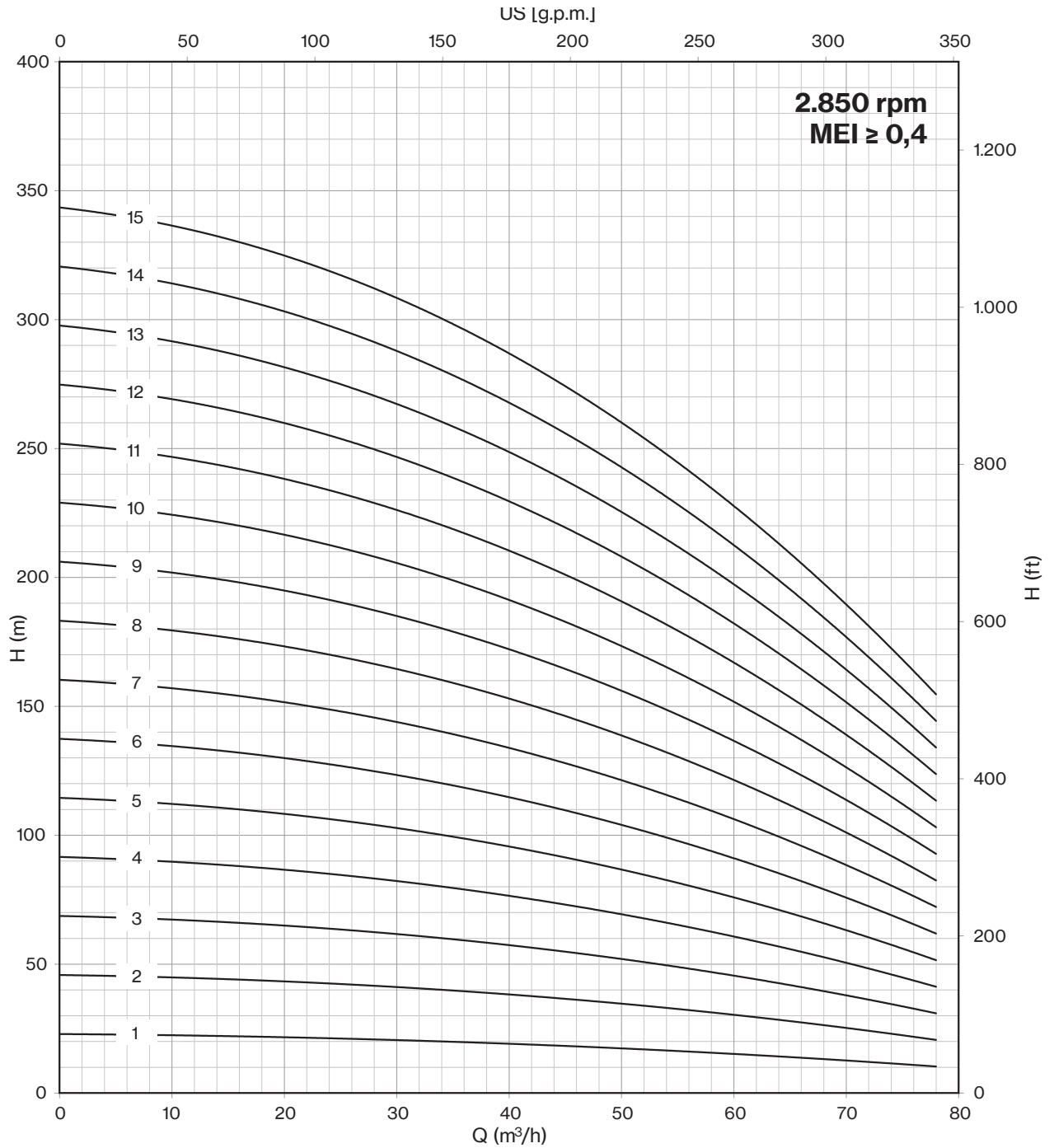

8LR 62

Motor 50 Hz - 2900 rpm				Q									
TYPE	Power		400 V	l/min l/sec m ³ /h	0	300	600	800	900	1000	1100	1200	1300
	HP	kW			0	5,0	10,0	13,3	15,0	16,7	18,3	20,0	21,7
	A		0	18	36	48	54	60	66	72	78		
8LR 62/16	90	66	126,0	H[m]	368	344	320	288	264	240	216	192	168
8LR 62/17	90	66	126,0		391	366	340	306	281	255	230	204	179
8LR 62/18	100	75	143,2		414	387	360	324	297	270	243	216	189
8LR 62/19	100	75	143,2		437	409	380	342	314	285	257	228	200
8LR 62/20*	125	92	175,1		460	430	400	360	330	300	270	240	210
8LR 62/21*	125	92	175,1		483	452	420	378	347	315	284	252	221
8LR 62/22*	125	92	175,1		506	473	440	396	363	330	297	264	231
8LR 62/23*	125	92	175,1		529	495	460	414	380	345	311	276	242
8LR 62/24*	125	92	175,1		552	516	480	432	396	360	324	288	252
8LR 62/25 D*	150	110	211,0		575	538	500	450	413	375	338	300	263
8LR 62/26 D*	150	110	211,0		598	559	520	468	429	390	351	312	273
8LR 62/27 D*	150	110	211,0		621	581	540	486	446	405	365	324	284
8LR 62/28 D*	150	110	211,0		644	602	560	504	462	420	378	336	294
8LR 62/29 D*	150	110	211,0		667	624	580	522	479	435	392	348	305
8LR 62/30 D*	175	130	245,3		690	645	600	540	495	450	405	360	315

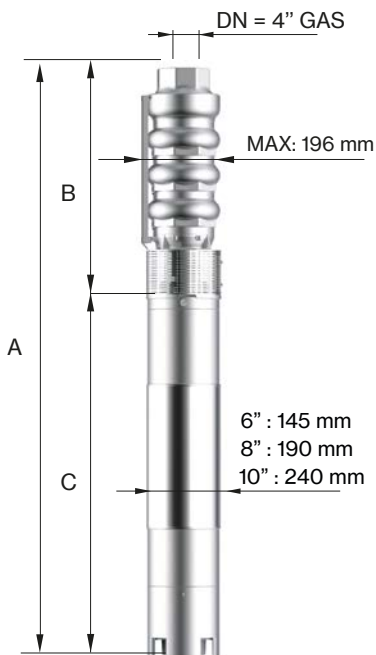

Motor 50 Hz 2900 rpm	DIMENSIONS (mm)			Weight (kg)	
TYPE	A	B	C	M	P
8LR 62/16	3020	1718	1302	214	114
8LR 62/17	3108	1806	1302	214	120
8LR 62/18	3277	1894	1383	230	127
8LR 62/19	3365	1982	1383	230	133
8LR 62/20*	3783	2200	1583	270	145
8LR 62/21*	3871	2288	1583	270	151
8LR 62/22*	3959	2376	1583	270	158
8LR 62/23*	4047	2464	1583	270	164
8LR 62/24*	4135	2552	1583	270	171
8LR 62/25 D*	4373	2640	1733	300	177
8LR 62/26 D*	4461	2728	1733	300	184
8LR 62/27 D*	4549	2816	1733	300	190
8LR 62/28 D*	4637	2904	1733	300	197
8LR 62/29 D*	4725	2992	1733	300	203
8LR 62/30 D*	4714	3080	1634	385	210

Max Eff. % =	74,5
Max kW / St. =	3,8

Q (flow)	25%	50%	75%	100%
NPSH (m)	3,4	3,4	6	8

* Coupled pump shaft
"D" Pump shaft in Duplex

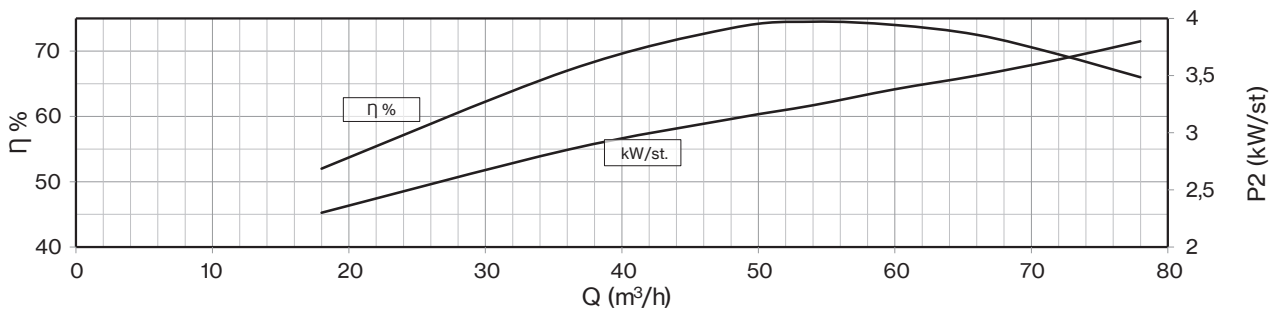
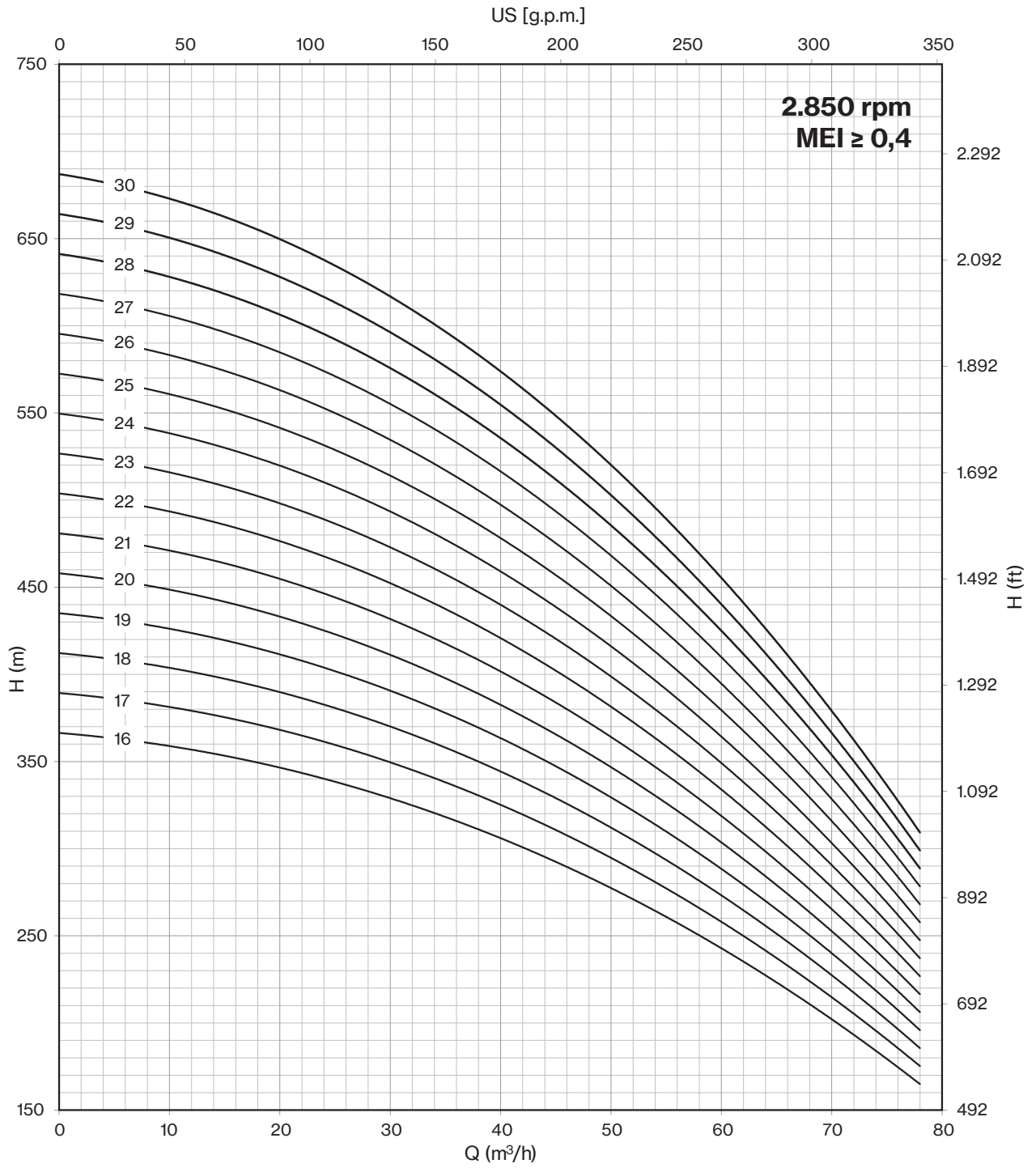

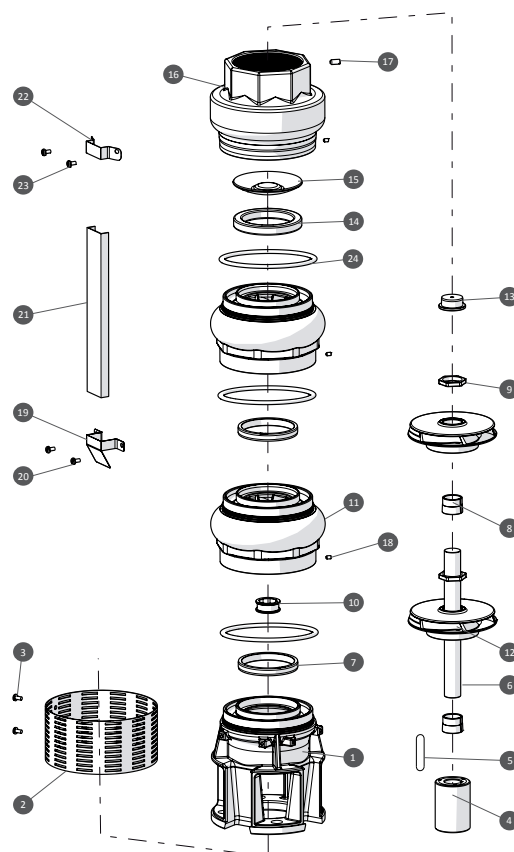

N° CODE	DESCRIPTION	LRS EXECUTION	LRX EXECUTION	LRD EXECUTION	(*) Q.TY
1	Motor bracket	AISI 304	AISI 316	Duplex	-
2	Suction strainer	AISI 304	AISI 316	Duplex	-
3	M4x8 screws for strainer	AISI 304	AISI 316	Duplex	-
4	Coupling	AISI 304	AISI 316	Duplex	1
5	Key	AISI 304	AISI 316	Duplex	1
6	Pump shaft	AISI 304	AISI 316	Duplex	1
7	Impeller wear ring	NBR	NBR	NBR	N° of St.
8	Conic collar	AISI 304	AISI 316	Duplex	N° of St.
9	Conic collar nut	AISI 304	AISI 316	Duplex	N° of St.
10	Diffuser bush bearing	NBR	NBR	NBR	N° of St.
11	Diffuser	AISI 304	AISI 316	Duplex	-
12	Impeller	AISI 304	AISI 316	Duplex	N° of St.
13	Reverse thrust ring	PTFE+25% CARBONE / Graphite	PTFE+25% CARBONE / Graphite	PTFE+25% CARBONE / Graphite	1
14	NRV gasket	NBR	NBR	NBR	1
15	Valve plate	AISI 304	AISI 316	Duplex	-
16	Delivery pump body	AISI 304	AISI 316	Duplex	-
17	Delivery body locking screw	AISI 304	AISI 316	Duplex	1
18	Diffuser locking screw	AISI 304	AISI 316	Duplex	N° of St.
19	Bottom cable guard clamp	AISI 304	AISI 316	Duplex	-
20	Bottom cable guard screws M4x8	AISI 304	AISI 316	Duplex	-
21	Cable guard	AISI 304	AISI 316	Duplex	-
22	Upper cable guard clamp	AISI 304	AISI 316	Duplex	-
23	Upper cable guard screws M4x8	AISI 304	AISI 316	Duplex	-
24	O-Ring	NBR	NBR	NBR	N° of St.

* Recommended spare parts quantity