

Installation and operation manual

EPIC

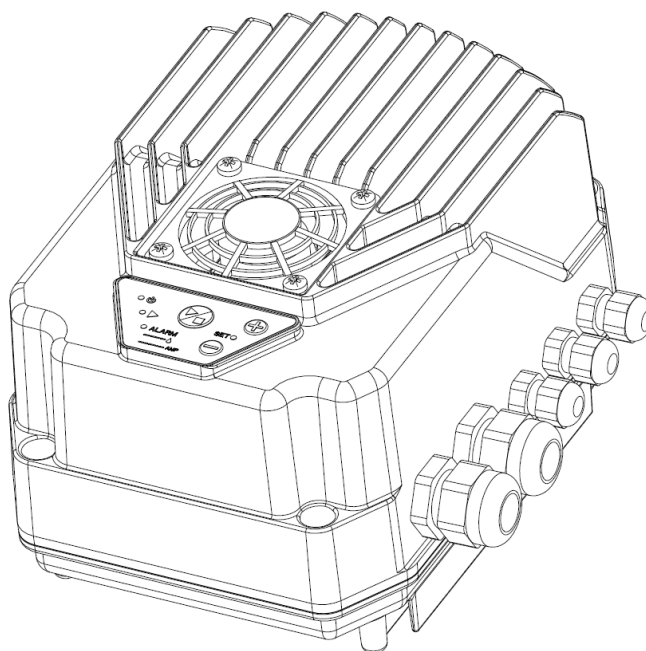

Table of contents

Cap.		Pag.
1	EPIC presentation	4
2	Safety warnings	4
3	Installation	4
4	Technical characteristics	4
5	Electrical connections	5
6	Mains protection and electromagnetic compatibility	7
7	Settings	7
8	Installation for constant pressure operation	7
9	Use and programming	8
10	COMBO operating mode	8
11	Alarms and warnings	9

1. EPIC presentation

EPIC is a control and protection device for pumping systems based on the power supply frequency variation of the pump.

EPIC guarantees:

- Energy and cost saving.
- Simplified installation and lower costs of the system.
- Extended durability of the system.
- Increased reliability.

EPIC guarantees pump operation to maintain the pressure constant according to the use conditions variations. This way, the pump, or pump system, is activated only when required, for the time required; as a result, energy waste is avoided and its durability is longer.

At the same time, EPIC can:

- Protect the motor against overload and dry operation and provide a relative alarm indication.
- Activate soft start and soft stop to extend system durability and reduce consumption peaks.
- Connect to another EPIC device for combined operation (COMBO).

2. Safety warnings

The manufacturer recommends reading the instruction manuals of his products carefully before their installation and use.



Any operation must be performed by qualified personnel.

Failure to comply with the recommendations provided in this manual, and in general, with the universal safety standards, may cause severe electric shocks or death.

The device must be connected to the mains via a switch/cut-out switch in order to guarantee disconnection from the power supply (even visual), before acting on the EPIC and on any connected load.

Disconnect the EPIC from the power supply before acting on the device and connected loads.

Never remove the cable gland plate or cover, before having disconnected EPIC from the power supply and waited for at least 5 minutes.

The EPIC system and pump must be accurately earthed before commissioning.

During the period in which EPIC is powered by the mains,

regardless of whether it is activating the load or is in standby mode (digital deactivation of the load), the motor output terminals remain live compared to the earth. This way, the opera-

tor is exposed to risks, as by seeing the load stopped, he/she may operate on the device.

We recommend tightening the 4 cover screws with relative washers before powering the device. Otherwise, the cover earth connection may fail causing electric shock or death.

Avoid impacts to the product or extreme climatic conditions during transport.

Make sure the product comes fully equipped with its accessories. In the event components are missing, immediately contact the supplier.

Damage to the product due to transport, installation, or improper use is not covered by the warranty of the manufacturer. Tampering with or disassembling any component will automatically make the warranty void and null.

The manufacturer declines any liability for damage to persons or objects due to improper use of his products.

3. Installation

EPIC can be mounted directly on the motor, replacing the terminal box. Refer to the manufacturer for compatibility and motor-EPIC coupling mode.

The device consists of two essential components.

- Coupling base
- Heat sink with electronic board

The heat sink part can be rotated by 180° to meet the application with vertical axes pumps.

4. Technical characteristics

Vin +/- 15%	Max Vout	Max I line	Max I out	P2 typical	Weig ht
[VAC]	[VAC]	[A]	[A]	[KW]	[kg]
1 x 230	3 x 230	11	7.5	1.5	2.5

- P.F. line side: 1 (in compliance with EN61000-3-2).
- Power supply frequency: 48 - 62 Hz .
- Max. operating temperature at nominal load: 40°C (104 °F).
- Maximum humidity relative to the installation environment: 50% at 40°C without condensation.
- Max. altitude at nominal load: 1000 m.
- Protection rate: IP55 (NEMA 4).
- Connectivity: RS 485 serial port for COMBO operation.

- PWM configurable: 2.5, 8 kHz.

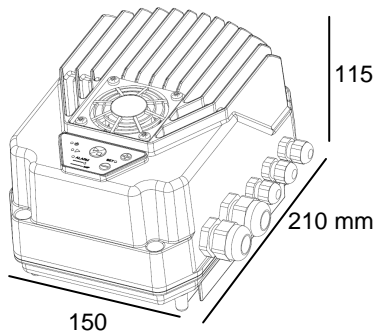

- **AN2:** analogue input 0-10 V
- **+10V:** power supply 10 VDC
- **0V:** reference 0V

To switch to the external frequency operation mode via analogue input AN2, connect the pressure sensor upon device activation.

The device will power the motor, which has variable frequency and is proportional to the AN2 analogue input signal.

Digital inputs IN1 and IN2 for motor start/stop:

- **IN1, 0V :** digital input 1
- **IN2, 0V :** digital input 2

Digital inputs 1 and 2 are non-voltage potential free contacts, which allow you to control the motor start/stop.

Both inputs are Normally Closed. Open one of the two contacts to stop the motor (e.g. floater).

Alarm output:

- **N.O. , COM :** the contact is closed in the presence of an alarm or power failure.
- **N.C. , COM:** the contact is open in the presence of an alarm.

Attention: Max. 250 VAC, 2A

RS485 serial for COMBO operation:

S+ , S-

Thanks to the RS485 serial connection, two devices can communicate with each other to allow the COMBO operation in a pressure unit.

We recommend using bipolar cables with minimum 0.35 mm section2.

Fan power supply (12 VDC):

- **VENT: + , -**

Attention: the fan start and stop depend on the temperature of the device.

Attention: Failure to comply with the polarities may damage the fan.



5. Electrical connections

Disconnect the EPIC from the power supply before acting on the device and connected loads. Read the chapter relative to electrical safety carefully.

Line power supply:

L1, L2, P.E.

Attention: we recommend using pre-insulated female faston terminals 6.3 x 0.8

Motor output:

- **U, V, W, (P.E.)**

Attention: we recommend using pre-insulated female faston terminals 6.3 x 0.8

Attention: follow the phase sequence to guarantee correct rotation direction of the motor.

Pressure sensor input:

- **AN1:** analogue input 4-20 mA
- **+15V:** sensor power supply 15 VDC

Attention: if the pressure sensor has only two wires, it is not necessary to connect the signal earth.

Attention: connect the shield of the shielded cable directly to the device earth.

External frequency signal input:

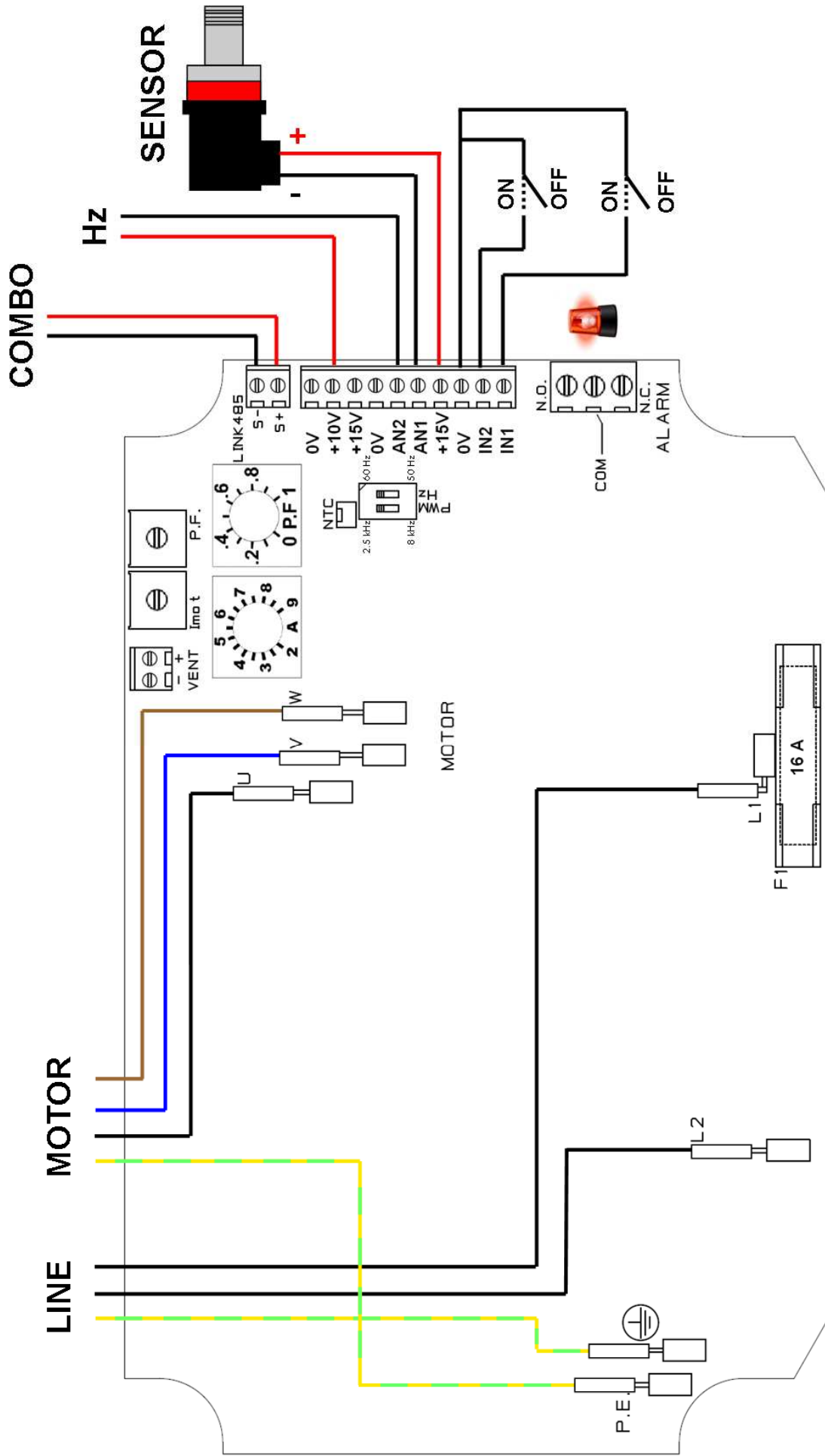

6. Mains protection and electromagnetic compatibility

The device is equipped with a 16 A delayed fuse (6.3 x 32 mm), as per standard.

The mains protection devices required upstream the device depend on the type of installation and local standards. We recommend using a circuit breaker protection with characteristic curve of type C and differential switch of type A.

Comply with the following provisions to guarantee electromagnetic compatibility (EMC) of the system:

- always connect the device to earth.
- if required, use shielded signal cables earthing the shield to one end only.
- install signal cables, motor cables and power supply separately.
- use motor cables as short as possible (< 1 m).

We recommend installing an additional inlet filter for particularly sensitive installation environments. (Available upon request).

7. Settings

PWM regulation and nominal Hz of the motor via dip-switch.

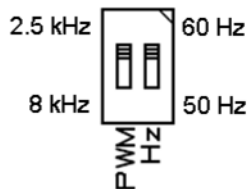

The dip-switch allows you to vary:

- Modulation frequency (PWM):
 - 8 kHz : suitable for device application on board the motor.
 - 2.5 kHz: suitable for wall-mounted application of the device and motor cables longer than 10 m.

Nominal frequency of the applied motor (50 Hz or 60 Hz). Attention: the 50 Hz setting with 60 Hz nominal frequency motor may reduce the provided performance. The 60 Hz setting with 50 Hz nominal frequency motor may produce motor overload and trigger an overload alarm.

Regulation of the maximum motor current threshold and P.F. (power factor or $\cos\phi$) threshold of dry operation.

The Imot trimmers and P.F. allow you to adjust the two alarm thresholds:

- **maximum motor current threshold:** when this value is exceeded, the device stops the load and triggers an over-current alarm. We recommend setting a maximum motor current threshold equal to the nominal current of the motor increased by 10%.
- **P.F. threshold of dry operation:** under this value, the device stops the load and triggers the dry operation alarm.

After 5 minutes from the stop, the device will attempt an automatic restart. In the event the attempt triggers an additional dry operation alarm, the pump stops for another 10 minutes before another attempt is carried out. Similarly, the attempts will be repeated automatically after 20, 40, 80 minutes. In the event all 5 attempts fail to restore the alarm, the device will stop the pump definitely. Therefore, to restore the operation, you must deactivate and activate the device manually.

To adjust the trimmer position correctly, we recommend referring to the indication below.

Generally, the P.F. value of the dry operation may vary be-

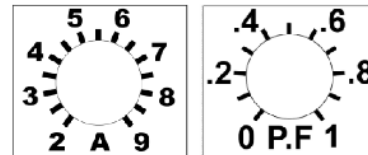

tween 60% and 70% compared to the nominal P.F. value of the pump.

8. Installation for constant pressure operation

The EPIC can manage the rotation speed of the pump in order to maintain pressure constant in a point of the system according to the water request variation of the utility.

The basic diagram of a pumping line that performs this operation is the following:

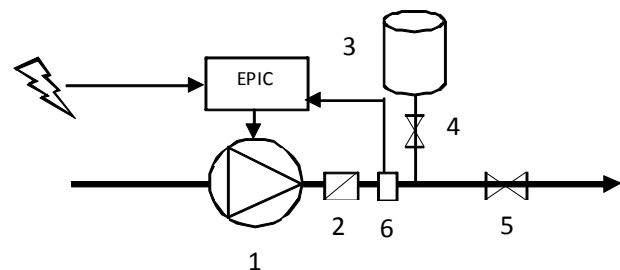

1. pump
2. check valve
3. expansion tank

4. valve
5. valve
6. pressure sensor

The expansion tank, in water systems equipped with EPIC, compensates leaks (or minimum water consumption) and maintains the pressure when the pump is stopped, preventing excessively frequent start/stop cycles. It is essential to choose the correct volume and pre-charge pressure of the expansion tank. Excessively low volumes do not allow effective compensation of minimum water consumptions or leaks when the pump is stopped. On the other hand, excessively high volumes complicate the control of the pressure made by EPIC, besides involving an economic and space waste.

Place an expansion tank with a volume equal to 10% of the maximum flow rate required, considered in litres/minute. E.g.: if the maximum flow rate required is 60 litres/min, use a 6-litre expansion tank.

The pre-charge pressure of the expansion tank must be equal to 80% of the operating pressure. E.g.: if the pressure set in EPIC, to which the system must be kept independently from water consumption, is 4 bar, the pre-charge pressure of the expansion tank must be about 3.2 bar.

9. Use and programming

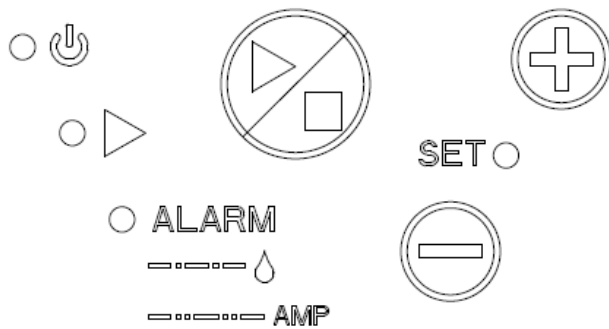

The red STANDBY LED switches on when the device is powered.

Then, the green SET LED starts blinking to indicate that the device is ready to start in a constant pressure control mode.

STARTING THE PUMP Press PLAY to start the pump. The green PLAY LED blinks with variable frequency: the closer the measured pressure is to the set pressure and the higher the frequency.

STOPPING THE PUMP
Press STOP to stop the pump. The green PLAY LED switches off.

MODIFICATION OF THE PRESSURE
Have a pressure gauge placed close to the pressure sensor. Open a tap with low flow to help the setting.

To modify the pressure:

- Start the pump.
- If the SET LED blinks, hold key + down until the SET LED remains on.
- Then press keys + or - to modify the pressure value.

MANUAL START UP OF THE PUMP WITH FIXED FREQUENCY

If the pressure sensor is disconnected or failed, the corresponding alarm is triggered (see alarm list). The pump can be started manually with fixed speed by holding the PLAY key down for at least 5 seconds.

The pump starts at a minimum frequency of 20 Hz. Press keys + or - to vary the frequency. If the SET LED is off, hold key + or - down until the SET LED switches on.

EXTERNAL FREQUENCY OPERATION The pump frequency (speed) can be varied with analogue input AN2 (0-10VDC).

Make sure the pressure sensor is not connected to analogue input AN1.

10. COMBO operating mode

To allow two EPIC devices to communicate with each other within a unit, connect the RS485 serial ports with a bipolar cable with minimum 0.35 mm² section.

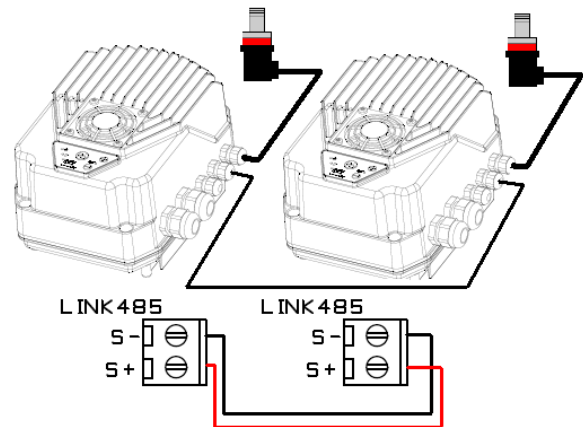

Every EPIC must be equipped with its pressure sensor in COMBO operating mode.

We recommend equipping every device with independent circuit breaker and residual current protection in order to guarantee the operation of the unit in the event one unit fails.

We recommend following the procedure below upon the first start up:

1. Connect the two devices via serial with power supply disconnected.
2. Power one of the two devices.
3. Wait at least 30 seconds and then power the second device.

The device that has been switched on first is the MASTER device of the unit (as indicated by the blinking SET LED), while the second device is called SLAVE.

To start/stop the unit in COMBO mode, press PLAY or STOP from the MASTER device (blinking SET LED).

Pressure must be adjusted always from the MASTER device.

In the event one of the two units fails or triggers an alarm, the other unit restarts operation after 1 minute from the stop, guaranteeing continuity of service.

The device can alternate the operation of the pumps to maintain the same operation hours and, therefore, their wear, facilitating programmed maintenance operations.

11. Alarms and warnings



- LED Off: No power supply
- LED On: Correct power supply (1 x 230 VAC +/- 15%)
- Blinking Red LED: under-voltage
- Blinking Red and Yellow LEDs: over-voltage



- LED On: motor on.
 - Pressure control: pump operation at the required pressure.
 - Fixed frequency / external frequency: pump operation at fixed frequency.
- Blinking LED: Pressure control pump with measured pressure different from the required pressure. The blinking frequency of the LED increases when the required pressure is about to be reached.



- Blinking LED: EPIC in constant pressure regulation mode and regulation buttons deactivated.

The SET LED switches on and regulation is activated by holding key + down for three seconds.

- LED off: EPIC in manual mode at fixed frequency or external frequency

In COMBO operating mode, the SET LED is off in the SLAVE device.

- LED On: regulation activated.

ALARM

The ALARM LED indicates an alarm based on a variable number of blinks followed by a three-second pause.

- 1 Blink: no water; automatic restore attempt after 5-10-20-40-80 minutes followed by definitive alarm (restart is possible only after deactivation).
- 2 Blinks: maximum motor current (consumed current higher than the set threshold).
- 3 Blinks: sensor alarm (no connected and efficient sensor, incorrect connection or output current lower than 2 mA).
- 4 Blinks: thermal alarm (NTC heat sink temperature higher than 70 °C).
- 5 Blinks: maximum inverter current alarm (restart is possible only after deactivation).
- 6 Blinks: master conflict alarm during COMBO operation (switch one of the inverters with triggered alarm off).
- 7 Blinks: no Master. Wait until the Slave becomes Master (it may require up to one minute)
- 8 Blinks: No control communication - power side (this alarm is normally triggered upon activation for a few seconds)
- Fast blinks without intermediate pauses: Digital inputs open.

