



Pump ideal for countercurrent swimming installation and can be used in water parks, fountains, waterfalls, etc. The pump body in polypropylene reinforced with glass fiber allows it to resist the chemicals of the pools and guarantee excellent durability.

Construction features

Painting	cataphoresis
Pump body, seal housing, diffuser	polypropylene + fiber glass
Motor bracket	aluminum
Impeller	Noryl®, marine bronze on request
Mechanical seal	ceramic-graphite-AISI 316
Motor shaft	stainless steel AISI 316
Liquid temperature	max 40 °C

Motor

2 poles induction motor	3~ 230/400V-50Hz
Insulation class	F
Protection degree	IP55



POOL5

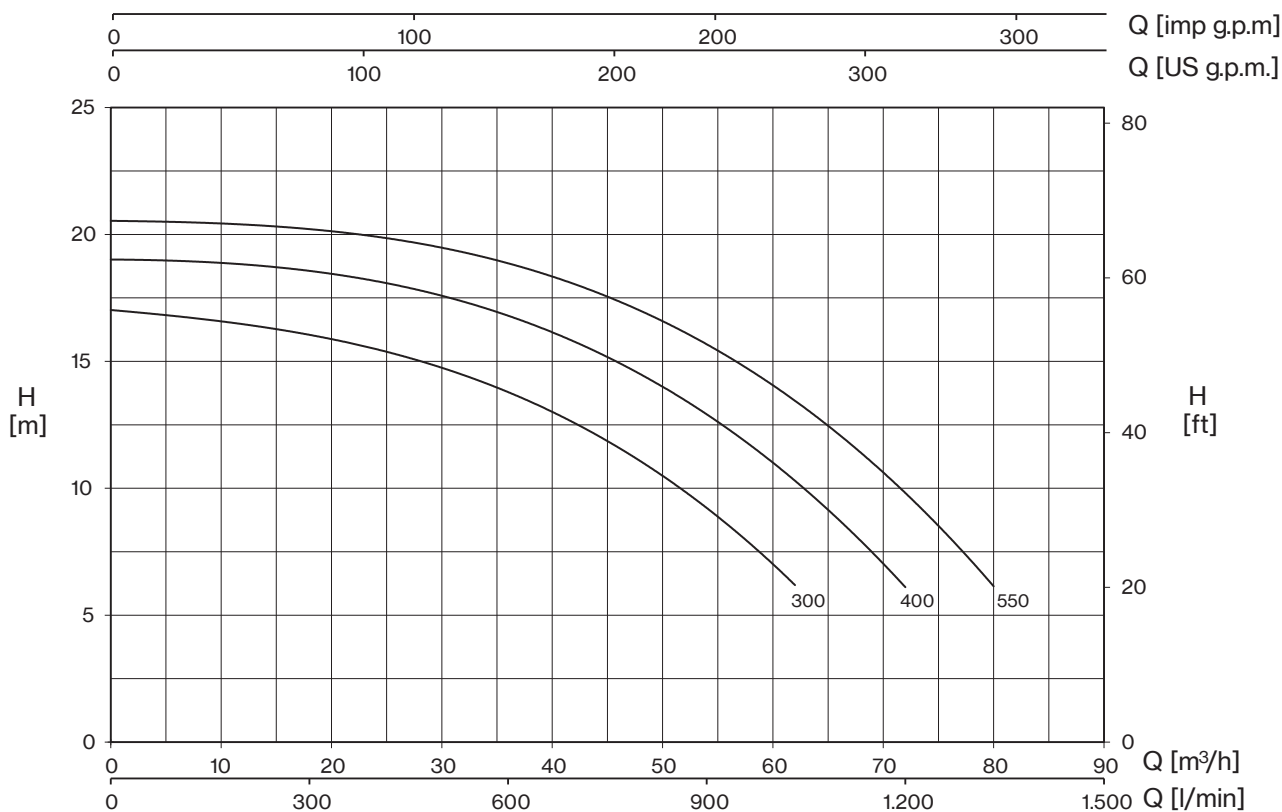

TYPE	P2		AMPERE		rpm	H (m)								DNA	DNM
			3~	3~		6	8	10	12	14	16	18	20		
3~	HP	kW	230 V	400V	Q (m³/h)										
POOL5 300	3	2,2	9,4	5,3	2900	62	58	52	44	34	20				
POOL5 400	4	3	12,5	6,9	2900	72	68	63	57	50	40	27		PVC90	
POOL5 550	5,5	4		8,8	2900	80	76	72	67	60	52	41	26		

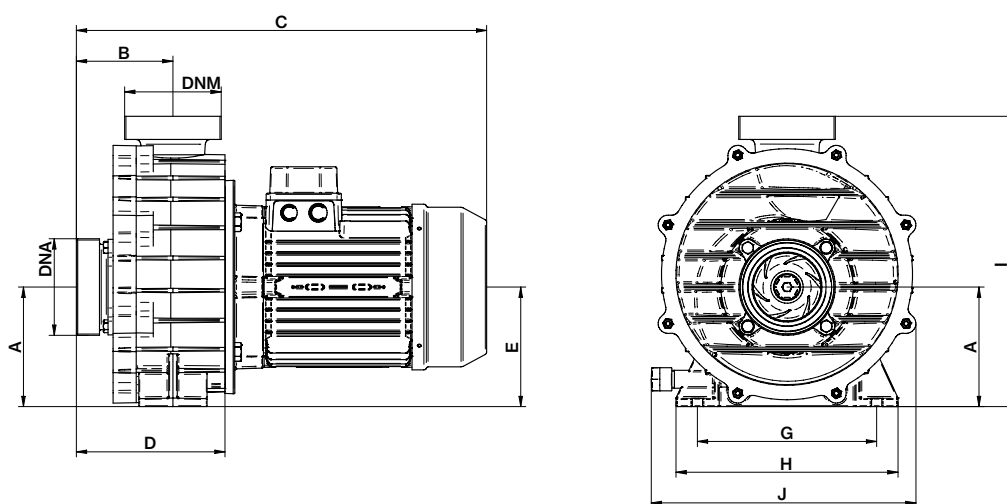

TYPE	DIMENSIONS (mm)										DNA	DNM
	A	B	C	D	E	G	H	I	J			
POOL5 300	140	113	480	174	140	210	260	340	310			
POOL5 400	140	113	480	174	140	210	260	340	310	PVC 90	PVC 90	
POOL5 550	140	113	480	174	140	210	260	340	310			