

Single-channel centrifugal drainage pumps: besides the high capacity they guarantee excellent head; ideal for civil and industrial applications; specifically designed for very heavy use; available in the mobile or permanent versions with coupling feet.

Construction features

Pump body	cast iron
 Impeller	cast iron
Mechanical seal	double seal with oil barrier; silicon carbide on pump side, ceramic-graphite on motor side
Motor shaft	stainless steel AISI 304
Free passage	Ø max 60 mm (FM 250/4-400/4 T) Ø max 90 mm (FM 550/4-750/4 T)
Max submergence	20 m
Liquid temperature	0 - 40 °C
Cable	H07 RN8F, 10 m
Bolts	A2 stainless steel
Foot support	galvanized iron
Gaskets	NBR rubber

Motor

4 Poles induction motor	3- 230V-50Hz 3- 400V-50Hz 3- 230/400V-50Hz 3- 400/690V-50Hz
Insulation class	F
Protection degree	IPX8

TYPE	LOTS			
	TRUCK		CONTAINER	
	PALLET (cm)	N° pumps	PALLET (cm)	N° pumps
FM 250-4/750-4 T	85×110×190	12	100×120×190	12

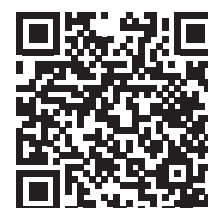

Q [imp g.p.m]
Q [US g.p.m.]

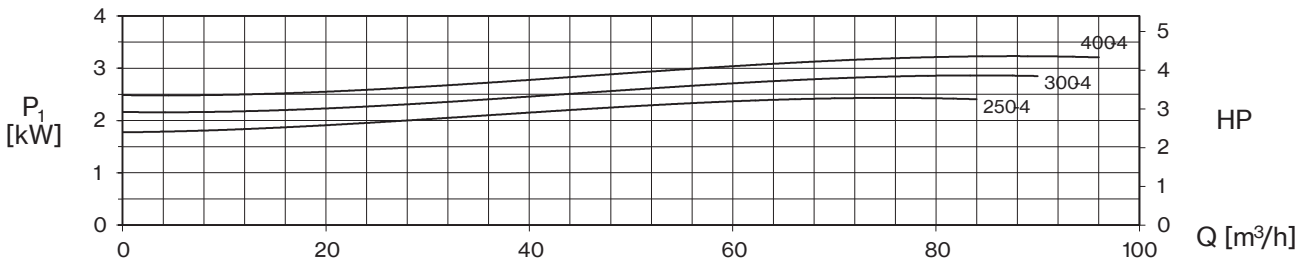
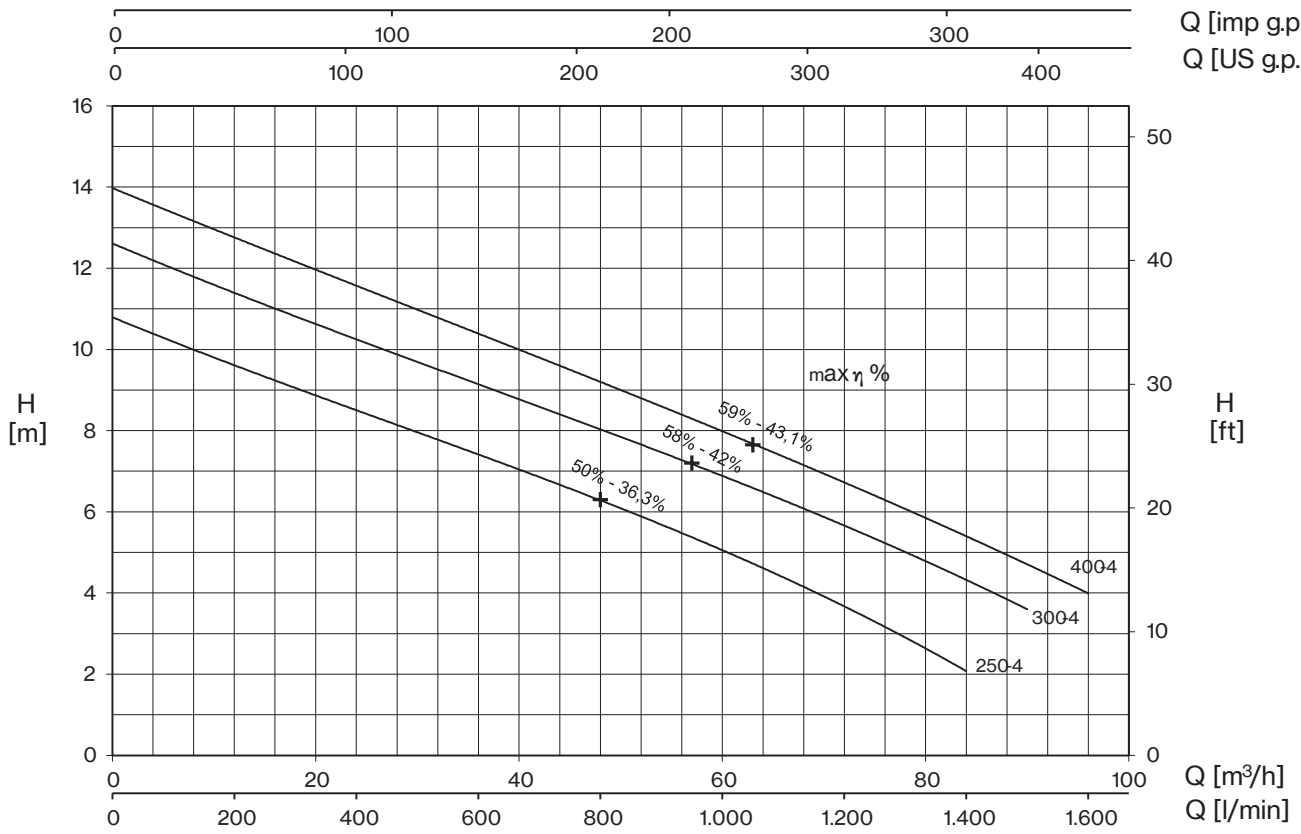

TYPE	AMPERE			
	3x230 V 50 Hz (*)	3x400 V 50 Hz	230/400 V 50 Hz λ / Δ (*)	400/690 V 50 Hz λ / Δ
FM 250-4 T	7,8	4,5	-	-
FM 300-4 T	9,0	5,2	-	-
FM 400-4 T	11,2	6,5	-	-

+ max η %

max hydraulic efficiency and respective total efficiency

(*) no standard execution

TYPE	P2		P1 (kW)	Q (m³/h - l/min)										
				0	12	24	36	48	60	72	84	90	96	
	HP	kW	3-	0	200	400	600	800	1000	1200	1400	1500	1600	
FM 250-4 T	2,5	1,8	2,4	10,8	9,6	8,5	7,4	6,3	5,1	3,6	2,1			
FM 300-4 T	3	2,2	2,9	12,6	11,4	10,3	9,1	8,0	6,9	5,7	4,3	3,6		
FM 400-4 T	4	3	3,2	14,0	12,7	11,6	10,4	9,2	8,0	6,7	5,4	4,7	4,0	

FM4

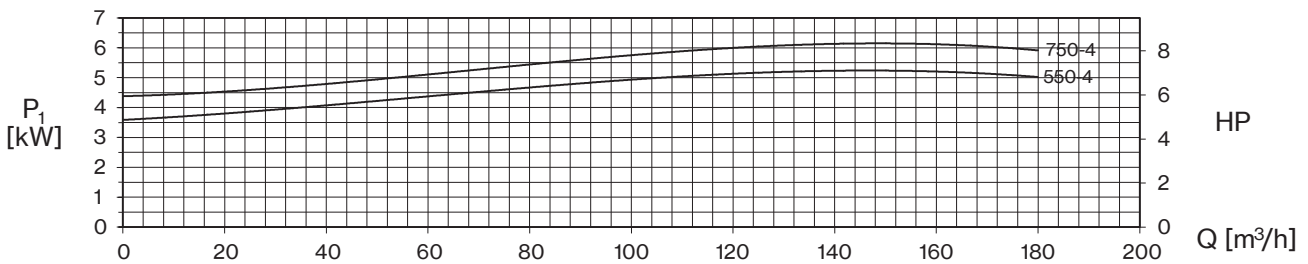
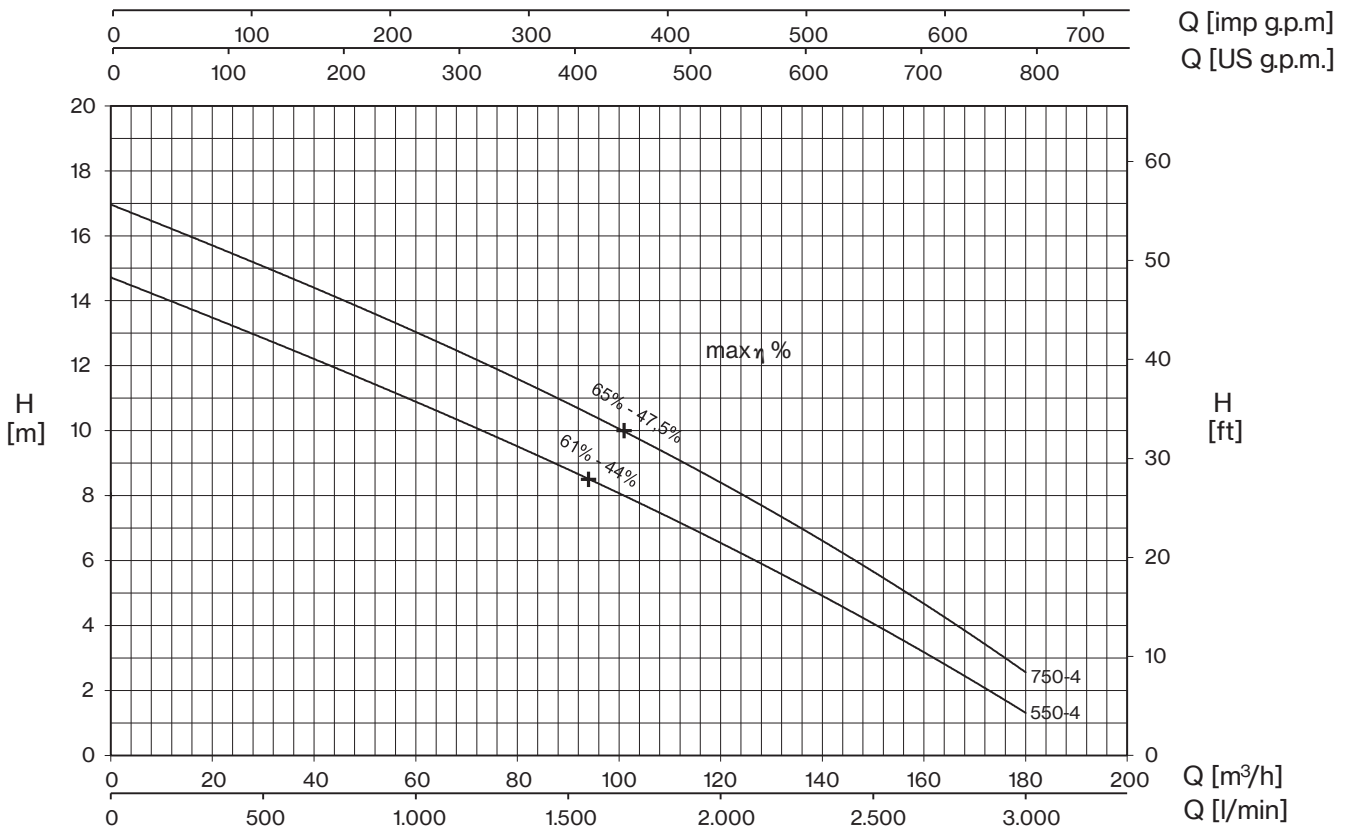

TYPE	AMPERE			
	3x230 V 50 Hz (*)	3x400 V 50 Hz	230/400 V 50 Hz λ / Δ (*)	400/690 V 50 Hz λ / Δ
FM 550-4 T	-	9,4	16,3	9,4
FM 750-4 T	-	11,8	20,4	11,8

+ max η %

max hydraulic efficiency and respective total efficiency

(*) no standard execution

TYPE	P2		P1 (kW)	Q (m³/h - l/min)															
				0	12	24	36	48	60	72	84	96	108	120	132	144	156	168	180
	HP	kW	3~	0	200	400	600	800	1000	1200	1400	1600	1800	2000	2200	2400	2600	2800	3000
FM 550-4 T	5,5	4	5,2	14,7	14,0	13,2	12,5	11,7	10,9	10,1	9,2	8,3	7,5	6,5	5,6	4,6	3,6	2,4	1,3
FM 750-4 T	7,5	5,5	6,1	17,0	16,2	15,4	14,7	13,8	13,0	12,2	11,4	10,4	9,4	8,4	7,3	6,2	5,1	3,8	2,6

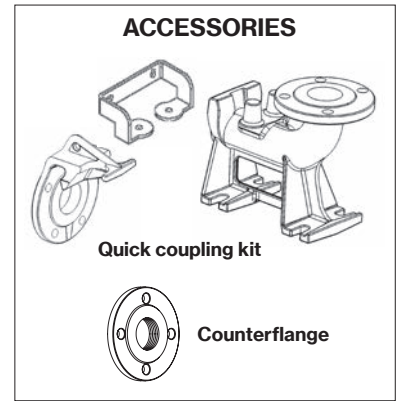
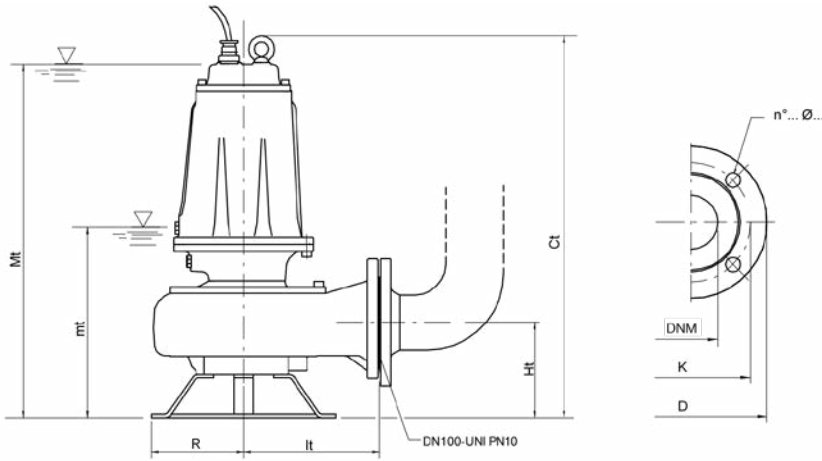

mt: minimum working level
 Mt: minimum submersion level for continuous duty

TYPE	DIMENSIONS (mm)							Kg
	Ct	Ht	R	lt	mt	Mt	DNM	
FM 250-4 T	660	165	160	235	300	614	100	71,5
FM 300-4 T	660	165	160	235	300	614	100	74
FM 400-4 T	660	165	160	235	300	614	100	77,5
FM 550-4 T	715	195	180	276	385	695	100	104
FM 750-4T	715	195	180	276	385	695	100	107,5

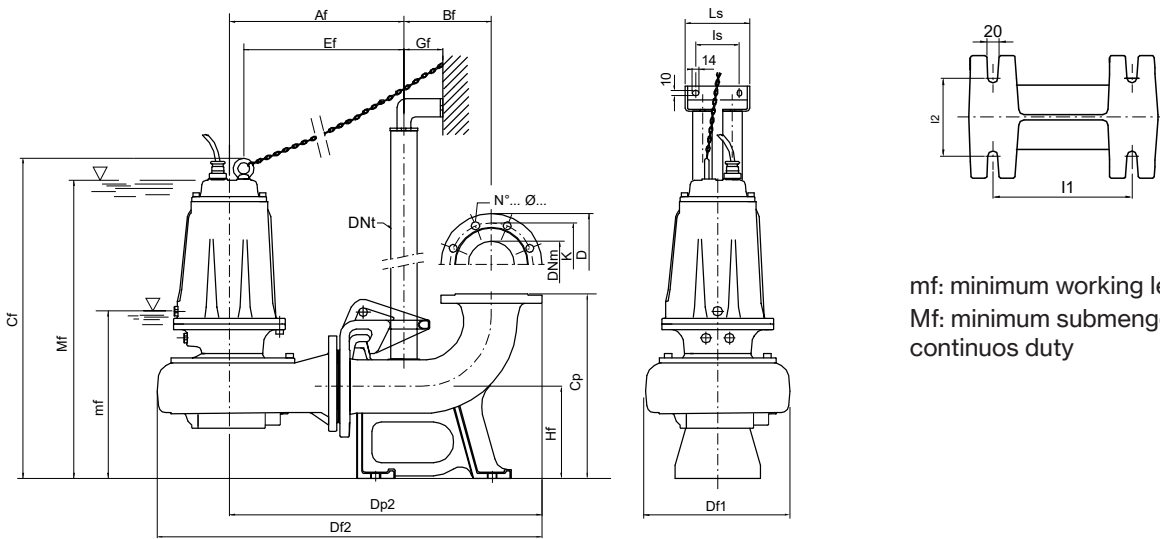

mf: minimum working level
 Mf: minimum submersion level for continuous duty

TYPE	DIMENSIONS (mm)																	
	Af	Bf	Cf	Cp	Df1	Df2	Dp2	Dnt	Ef	Gf	Hf	l1	l2	ls	Ls	mf	Mf	DNM
FM 250-4 T/P	378	190	695	400	317	835	678	2"	347	85	200	250	140	130	180	335	650	100
FM 300-4 T/P	378	190	695	400	317	835	678	2"	347	85	200	250	140	130	180	335	650	100
FM 400-4 T/P	378	190	695	400	317	835	678	2"	347	85	200	250	140	130	180	335	650	100
FM 550-4 T/P	419	190	755	400	371	900	719	2"	384	85	200	250	140	130	180	390	700	100
FM 750-4 T/P	419	190	755	400	371	900	719	2"	384	85	200	250	140	130	180	390	700	100

Flange UNI PN 10 (mm)			
DNM	K	D	n°... Ø...
100	180	220	8... 18...

TYPE	PROTECTION	1 PUMP CONTROL PANEL		2 PUMPS CONTROL PANEL	
	3 x 400 V	3 x 400 V	400 / 690 V	3 x 400 V	400 / 690 V
FM 250-4 T	PT 40-50/5.7-9.1	EQSMT 10		EQ2SMT 10	
FM 300-4 T	PT 40-50/5.7-9.1	EQSMT 10		EQ2SMT 10	
FM 400-4 T	PT 40-50/5.7-9.1	EQSMT 10		EQ2SMT 10	
FM 550-4 T	PT 55-75/8.6-13.5	EQSMT 10		EQ2SMT 10	
FM 750-4 T	PT 100/12.5-16.5	EQSMT 10	QST 5	EQ2SMT 10	Q2ST 5